

Scope of Supply/Bill of Material & Mounting Drawings

Part Number: R-HM18-14-01-SL

Part Description: Large Side Stand – Royal Enfield Himalayan

Installation / Parts List / Bill of Material for Mounting

NO.	Description	Quantity	Torque * (N-M)	Remarks **
1	Bottom Plate	1		
2	Middle Plate	1		
3	Top Plate	1		
4	Screw M6 X 20	4	15	Use Liquid Thread Locker
5	Nut M6	4	15	Use Liquid Thread Locker
SRC Design uses Metric System of Measurement and all dimensions in Millimeters				
* Recommended to use the Torque specified in the table				
** Denotes Usage of Liquid Thread Locker in specified Locations				

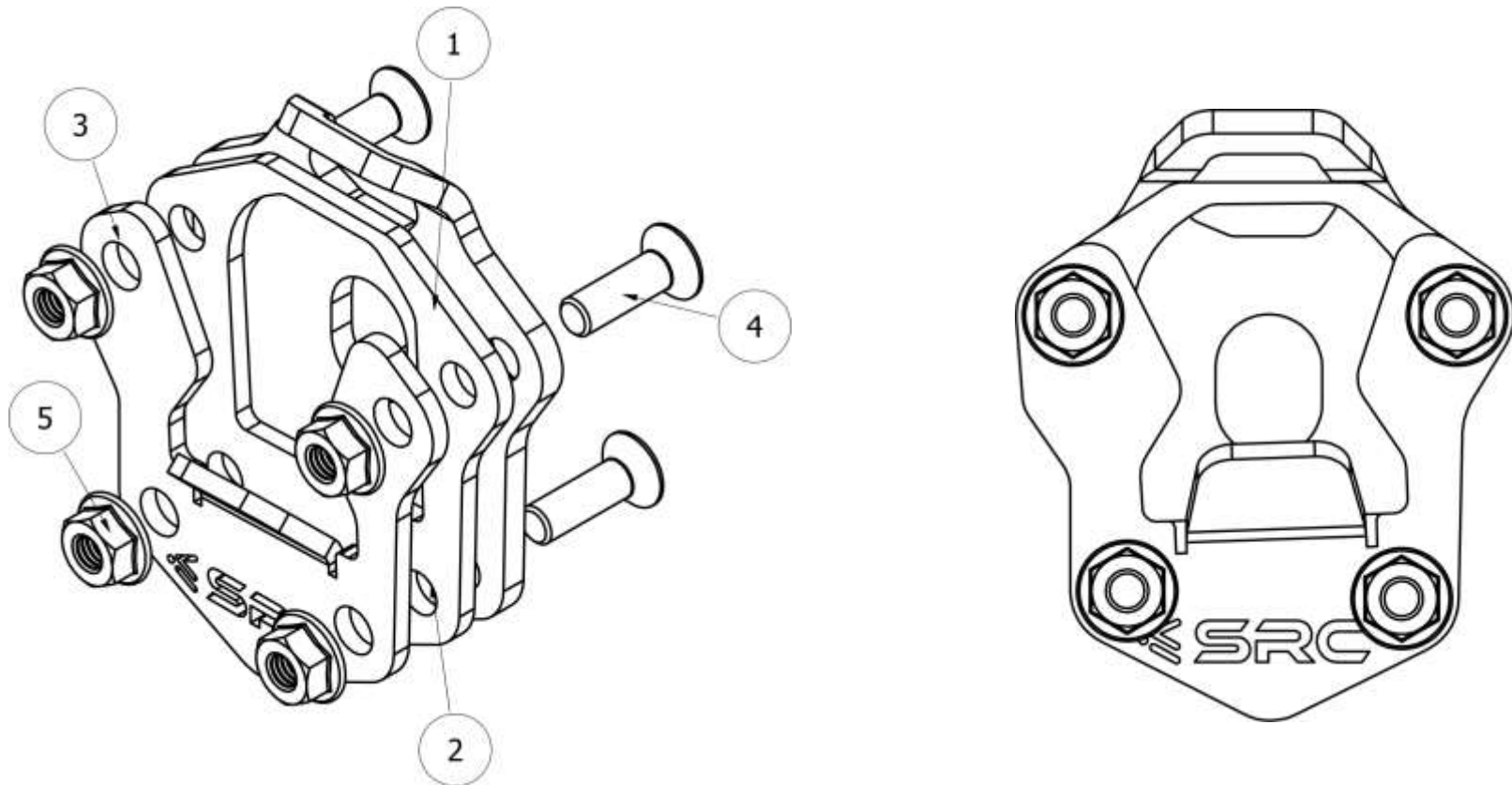

MOUNTING DRAWINGS

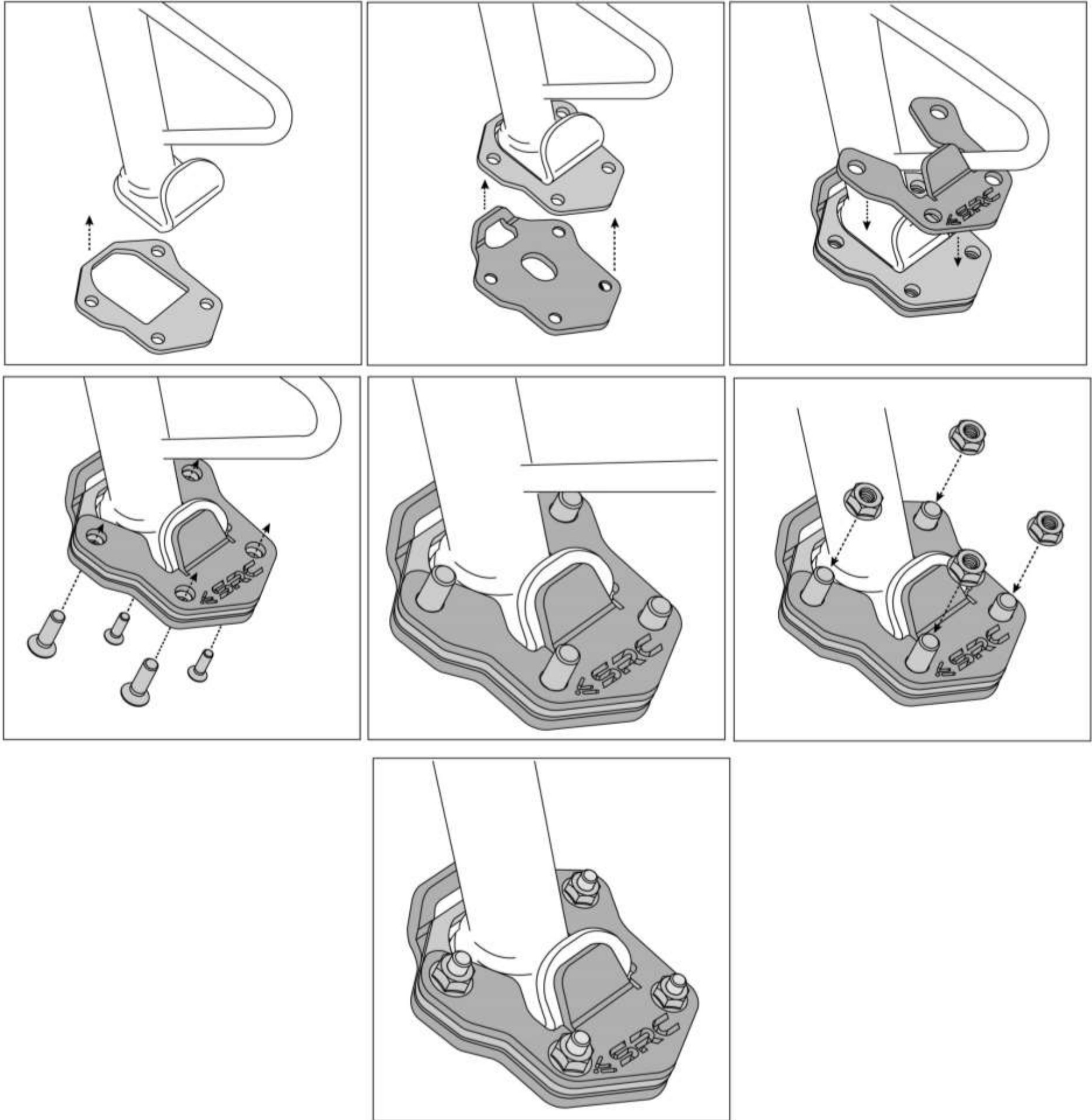

Step 1:

During Mounting the Large Side Stand, let the Motorbike firmly rest on the floor, using the Centre Stand.

The Middle Plate (2) serves as the Sandwich between the Top Plate and the Bottom plate. Orient the Middle Plate (2) as shown in the drawing. It has a cut-out and it clears the Side stand base, but slightly hugs the Side stand base, around its periphery.

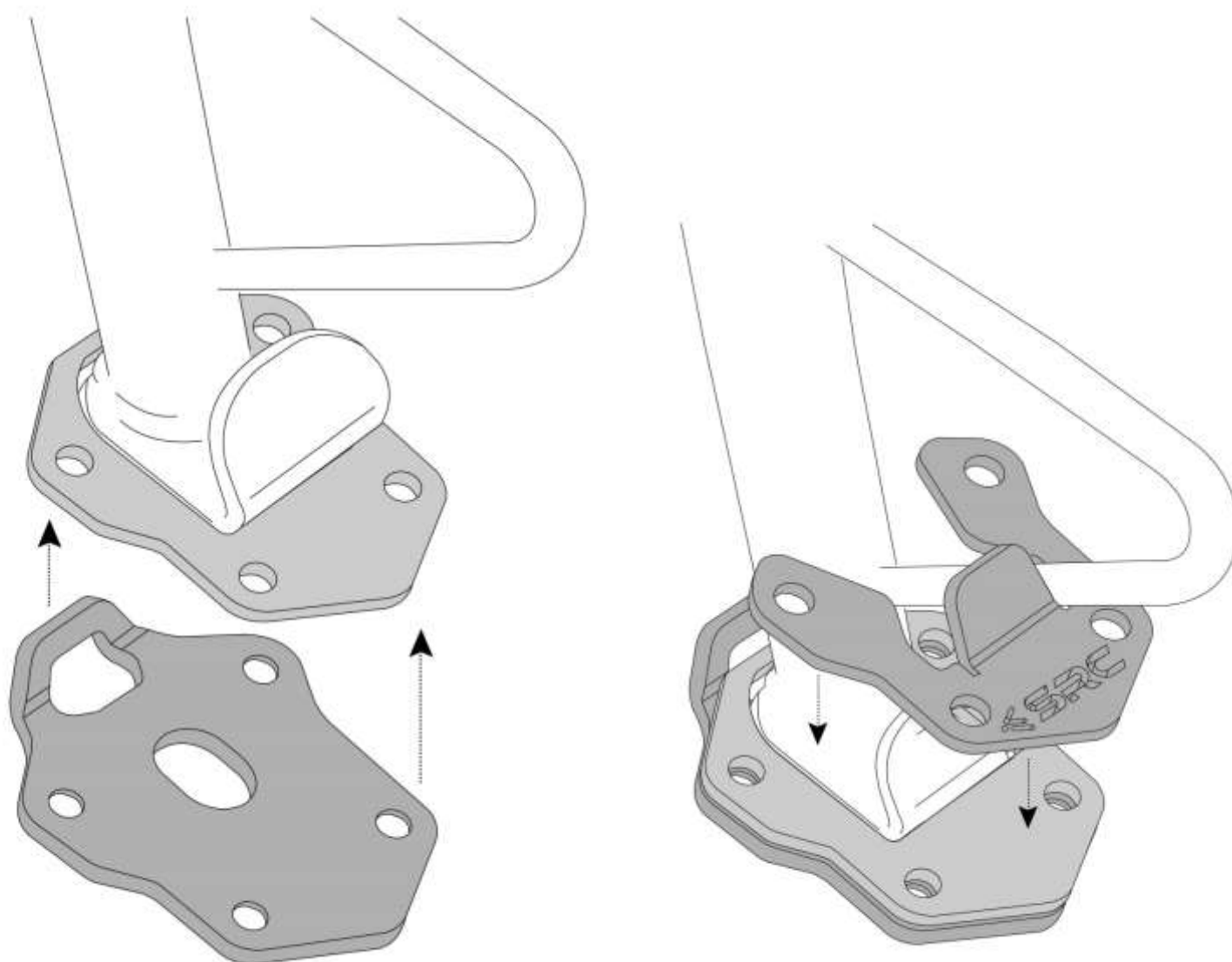
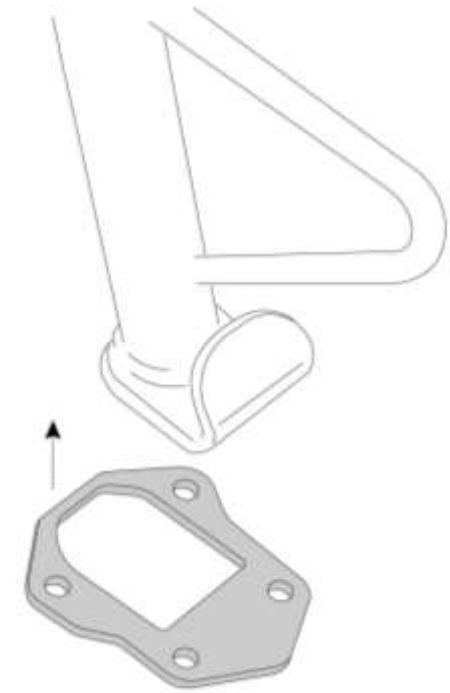

Step 2:

Orient the Bottom plate (1) as shown in the drawing and visually orient and align the 4 mounting holes of the bottom plate and the Middle Plate (2).

Orient the Top plate (3), as shown in the drawing (it has the cut-out to clear the gusset feature of the Side stand) and visually orient the 4 mounting holes to the plate clusters below.

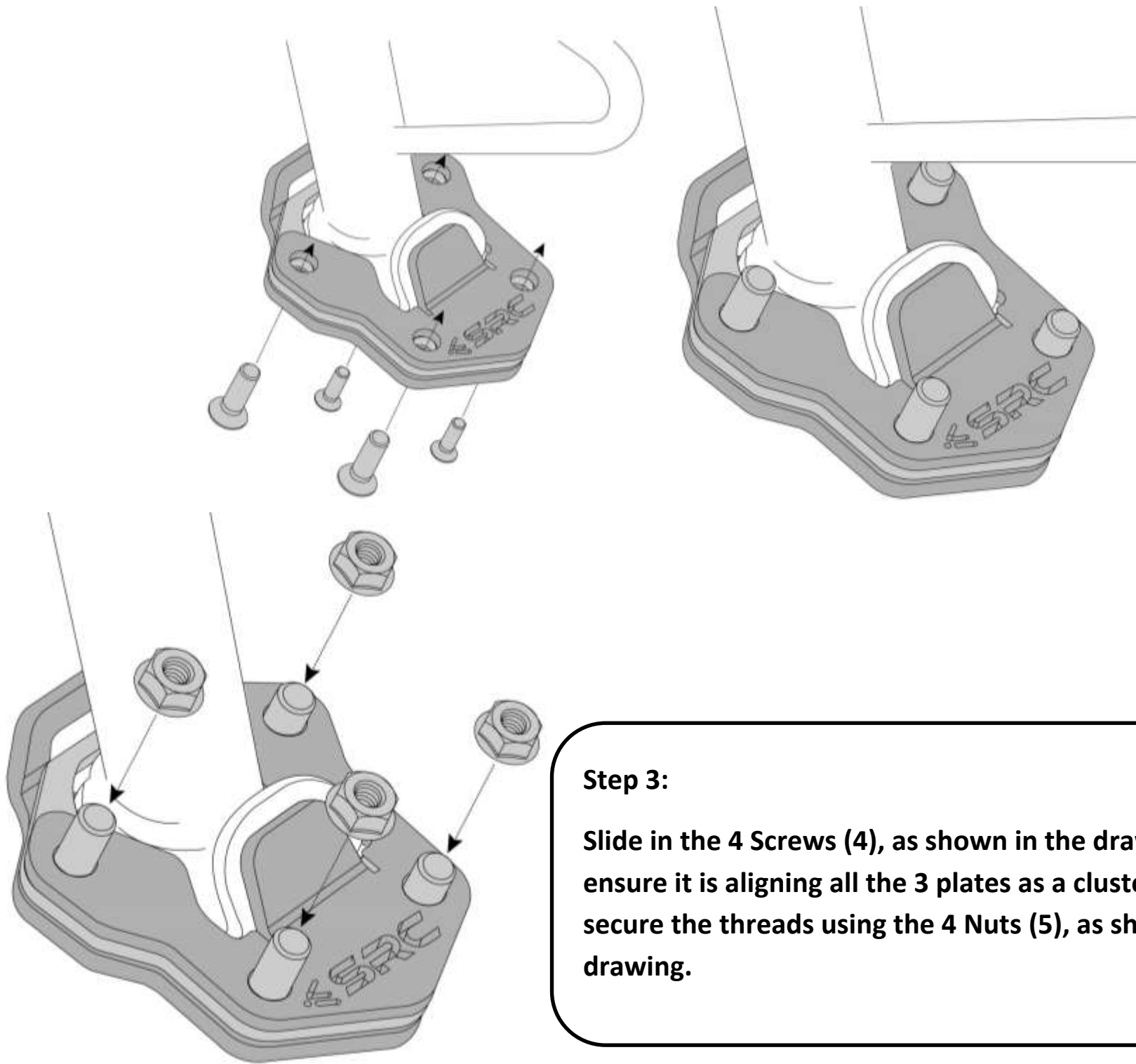

Step 3:

Slide in the 4 Screws (4), as shown in the drawing, and ensure it is aligning all the 3 plates as a cluster and secure the threads using the 4 Nuts (5), as shown in the drawing.

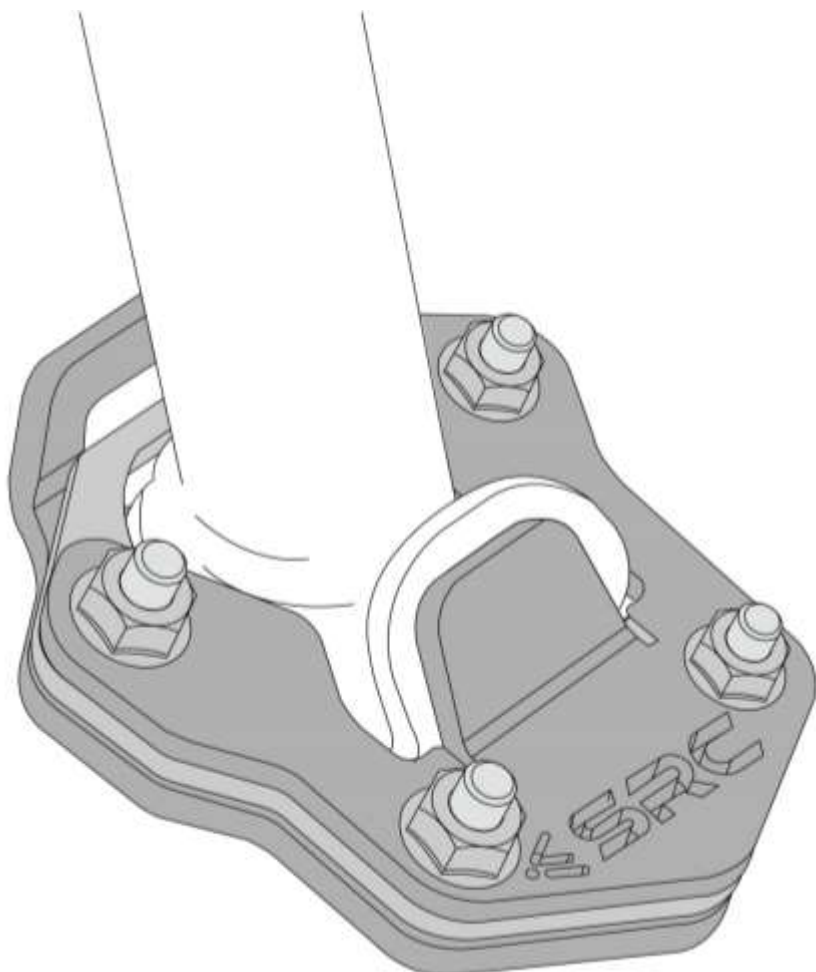

Step 4:

The threads can be tightened to the torque, as given in the table.

The above drawing represents the “As Is Mounted Condition” of the Large Side Stand. It improves the foot print of the OE feature and improves the static stability, when the Motorbike is parked using the Side stand.



General Instructions

- 1. We request you to pay attention to the Mounting Instructions in this document and follow the step-by-step procedures.**
- 2. This Mounting Instruction manual is a “Do It Yourself” (DIY) fitment manual of the Accessory part to the Vehicle. We have prepared this based on our experience and knowledge, related to the Vehicle, Part and its functional aspects.**
- 3. SRC cannot guarantee the interchangeability of the parts to any other manufacturer’s accessory part. It is advised to the User, to inspect and ensure the original state of all other Vehicle parts.**
- 4. We request you to bear in mind, that the Installed part can change the driving behaviour and/or the stability during driving or any other dynamic conditions.**
- 5. If you have the appropriate tools and another person to assist you in the mounting, it will help.**
- 6. After Completion of the Mounting and before taking on a First ride, Ensure and Check all functions of the Vehicle. It is always advised to check loosening of the fasteners after the first 50 kilo meters of ride and at regular intervals.**
- 7. We are showing here the Scope of Supply/ Installation/Parts list & BOM from SRC**
- 8. To the maximum extent possible, our design use the current Mounting/Fitment of the Original Equipment, so that Installation of these accessories will not affect the Payload or Function of the Vehicle or the Part on which it is mounted to protect it**
- 9. If any additional modifications are to be done, prior to the fitment of the accessories, it will be explicitly specified in the instruction sheets.**