

## Scope of Supply/Bill of Material & Mounting Drawings

Part Number: H-CRF300L-14-01-SL

Part Description: Large Side Stand – HONDA CRF300L

### Installation / Parts List / Bill of Material for Mounting

NO.	Description	Quantity	Torque * (N-M)	Remarks **	Check List
1	Top Plate	1			
2	Middle Plate	1			
3	Low Plate	1			
4	Bush 15x4	4			
5	Countersink Screw M6 X 20	4	9 - 10	Use Liquid Thread Locker	
6	Nut M6	4			

SRC Design uses Metric System of Measurement and all dimensions in Millimeters

\* Recommended to use the Torque specified in the table

\*\* Denotes Usage of Liquid Thread Locker in specified Locations

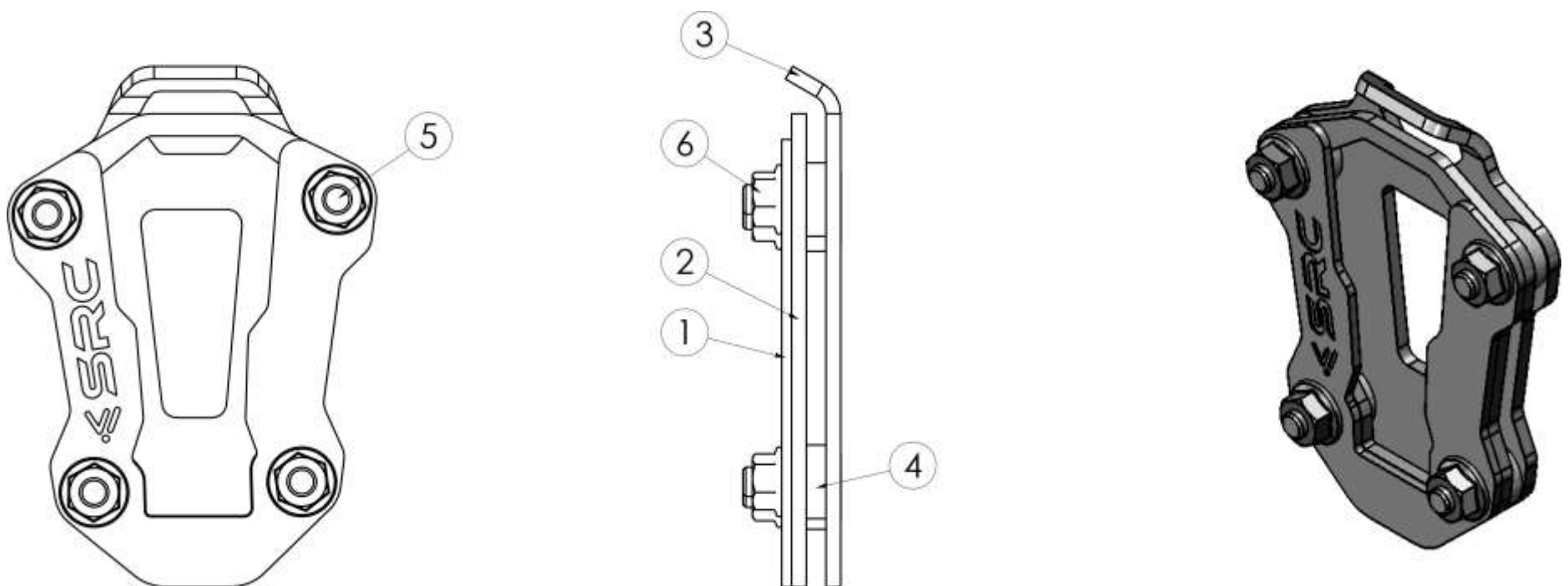

## Mounting Instructions

### Step 1:

**Orient and Slip-in the Middle Plate (2), as shown.**

**The peripheral Inner walls of the Middle plate, will closely hug the outer walls of the Side stand.**

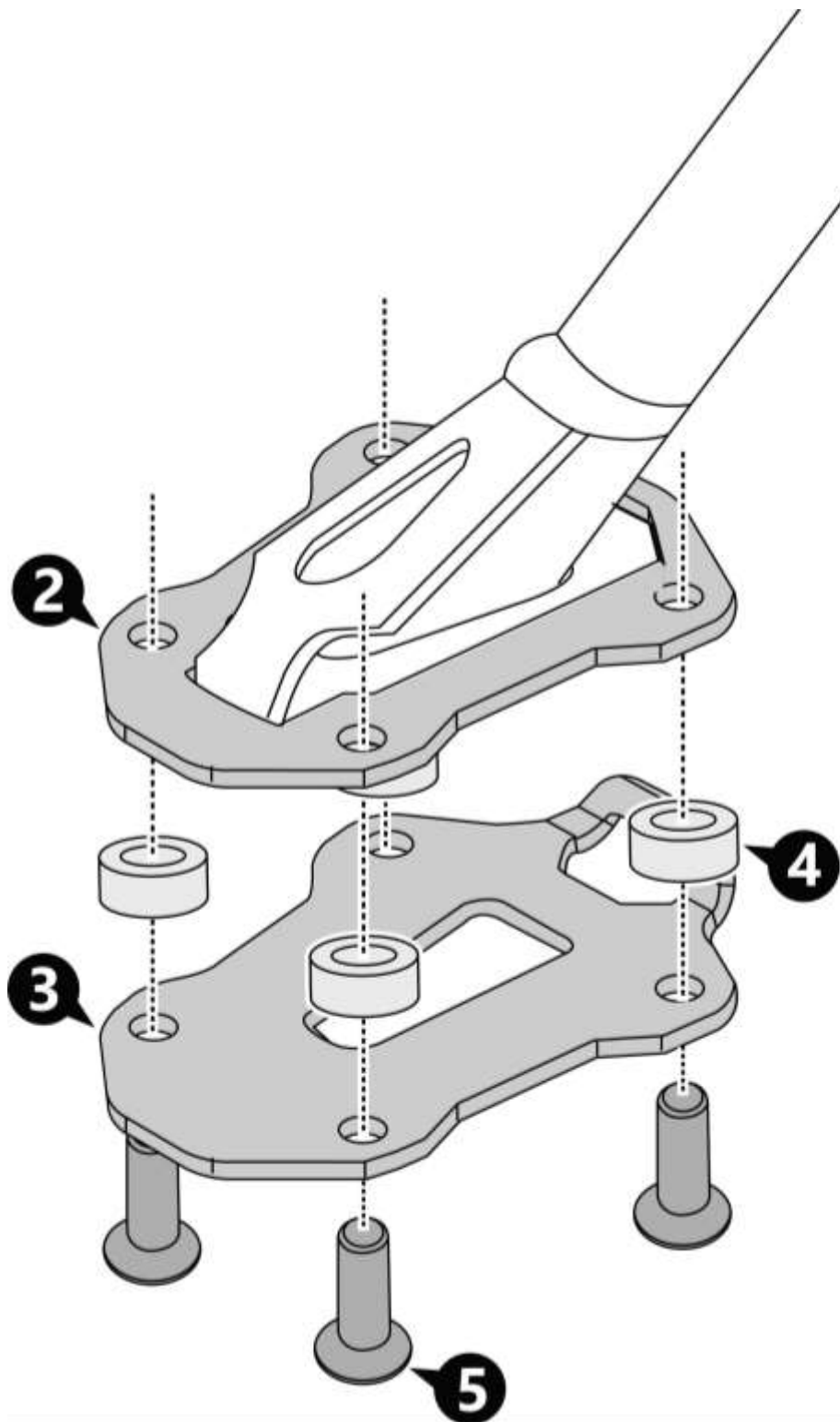
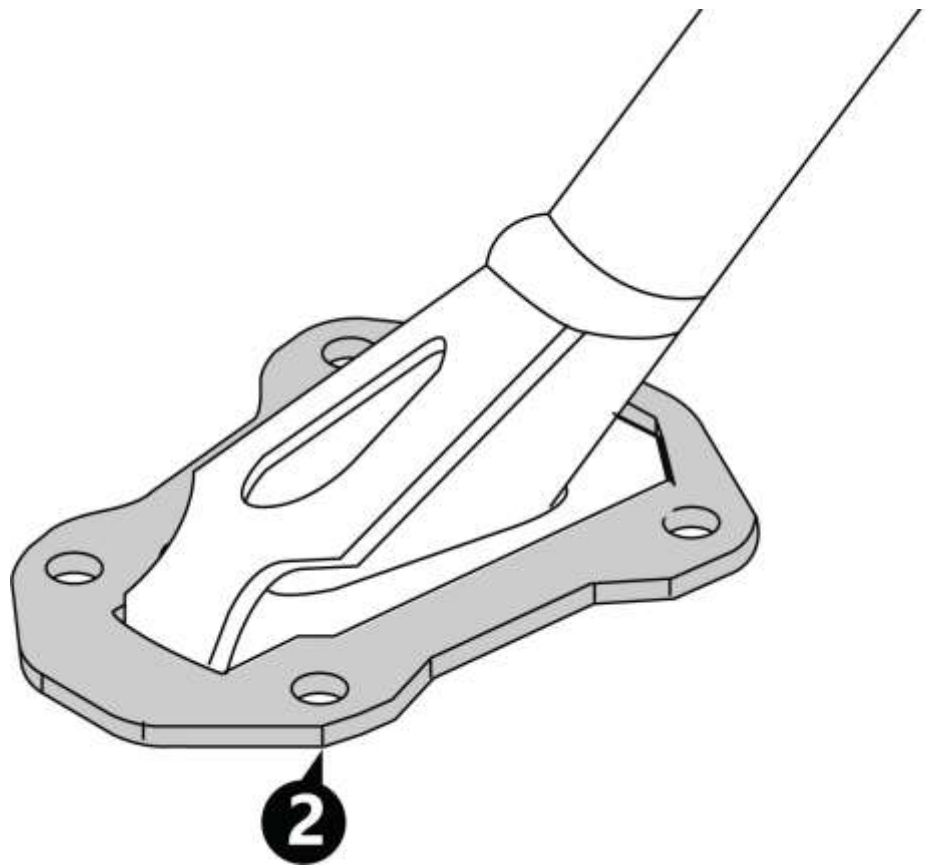

### Step 2:

**Orient and Align the Middle Plate (2), Bush (4) and Low Plate (3), all in-line, to the 4 Mounting holes.**

**The Inner walls of the Middle plate will closely hug with the outer walls of the Side stand.**

**The Bottom plate will have a rear flap, which when mounted in-line with the 4 holes, suitably, sandwiches the 3 plates together.**

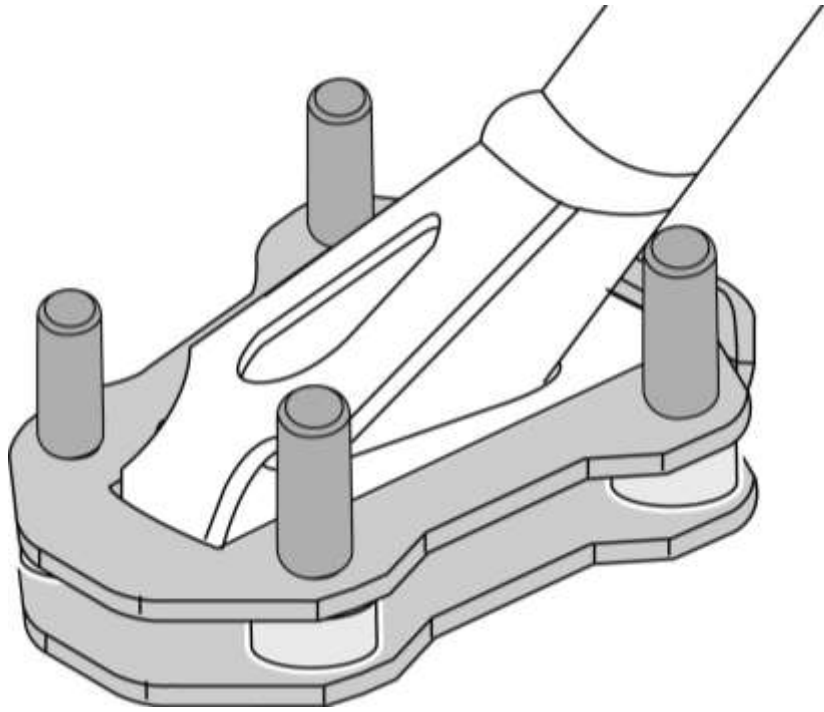

**Step 3:**

**As shown in the left of the Side Stand**

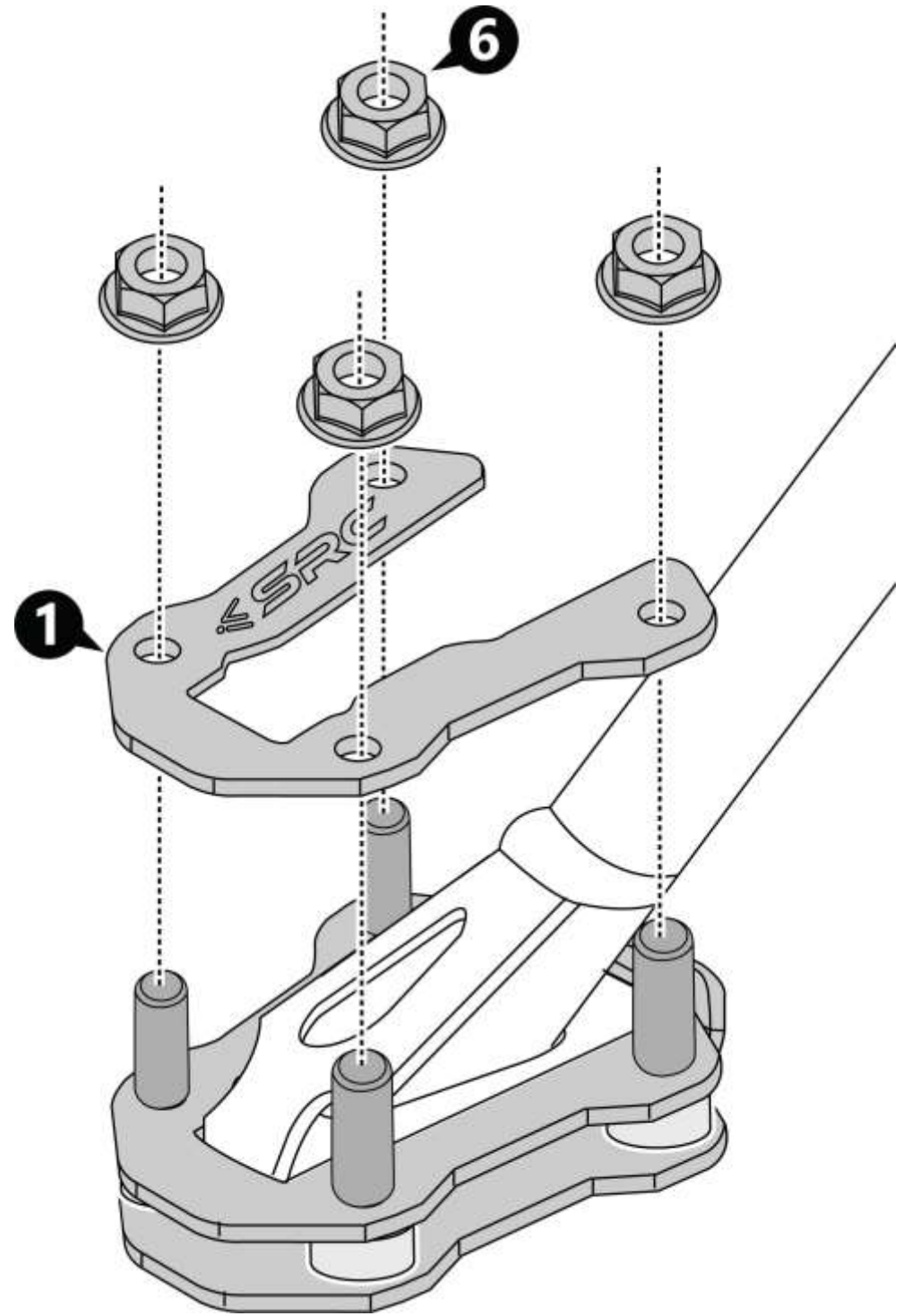

**Step 4:**

**Slide-in the Top Plate (1), as shown and orient the mounting holes in-line with the 4 Projecting screws.**

**Secure the threads on the screw using M6 Nut (6), as shown.**

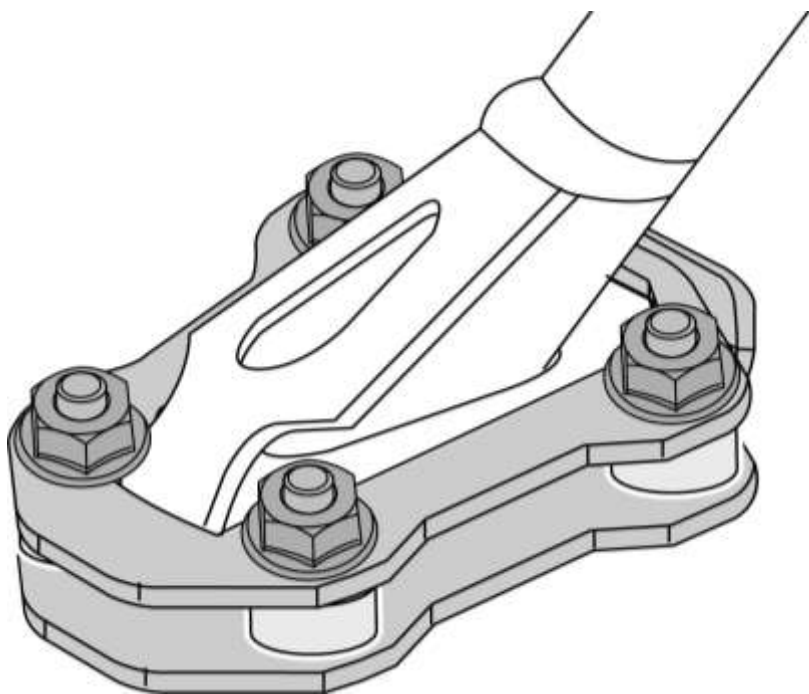

**As shown in the left, is the Final Mounted condition of the Side Stand**



## General Instructions

- 1. We request you to pay attention to the Mounting Instructions in this document and follow the step-by-step procedures.**
- 2. This Mounting Instruction manual is a “Do It Yourself” (DIY) fitment manual of the Accessory part to the Vehicle. We have prepared this based on our experience and knowledge, related to the Vehicle, Part and its functional aspects.**
- 3. SRC cannot guarantee the interchangeability of the parts to any other manufacturer’s accessory part. It is advised to the User, to inspect and ensure the original state of all other Vehicle parts.**
- 4. We request you to bear in mind, that the Installed part can change the driving behaviour and/or the stability during driving or any other dynamic conditions.**
- 5. If you have the appropriate tools and another person to assist you in the mounting, it will help.**
- 6. After Completion of the Mounting and before taking on a First ride, Ensure and Check all functions of the Vehicle. It is always advised to check loosening of the fasteners after the first 50 kilo meters of ride and at regular intervals.**
- 7. We are showing here the Scope of Supply/ Installation/Parts list & BOM from SRC**
- 8. To the maximum extent possible, our design use the current Mounting/Fitment of the Original Equipment, so that Installation of these accessories will not affect the Payload or Function of the Vehicle or the Part on which it is mounted to protect it**
- 9. If any additional modifications are to be done, prior to the fitment of the accessories, it will be explicitly specified in the instruction sheets.**