

Scope of Supply/Bill of Material & Mounting Drawings

Part Number: H-CRF17-14-01-SL

Part Description: Large Side Stand – HONDA CRF250 RALLY

Installation / Parts List / Bill of Material for Mounting

No.	Description	Quantity	Torque * (N-m)	Remarks **
1	Bottom Plate	1		
2	Top Plate	1		
3	Countersink Screw M6 x 20	4		
4	Middle Plate	1		
5	Nut M6	4	15	Use Liquid Thread Locker
SRC Design uses Metric System of Measurement and all dimensions are in Millimeters				
* Recommended to use the Torque specified in the table				
** Denotes Usage of Liquid Thread Locker in specified locations				

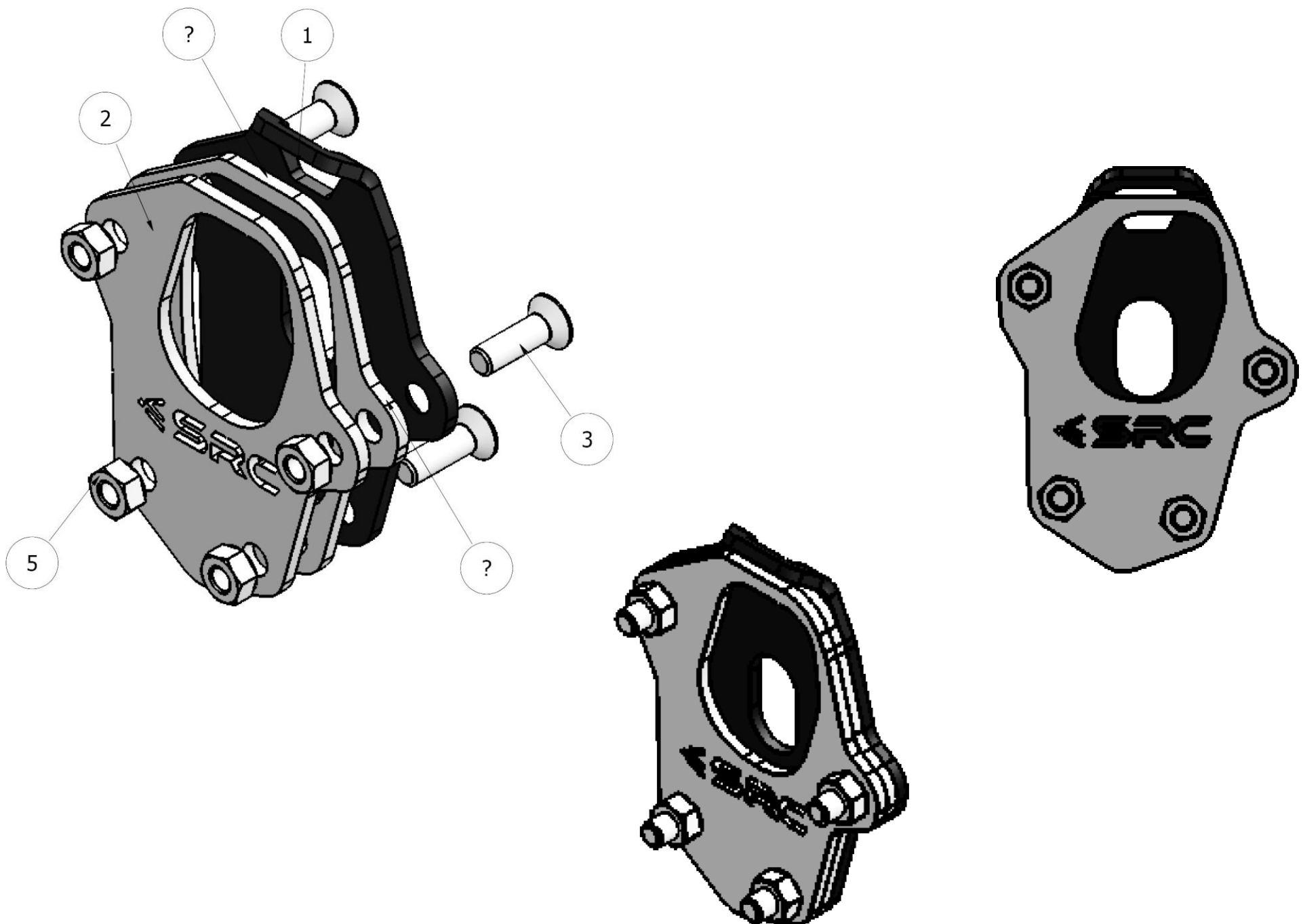

MOUNTING DRAWINGS

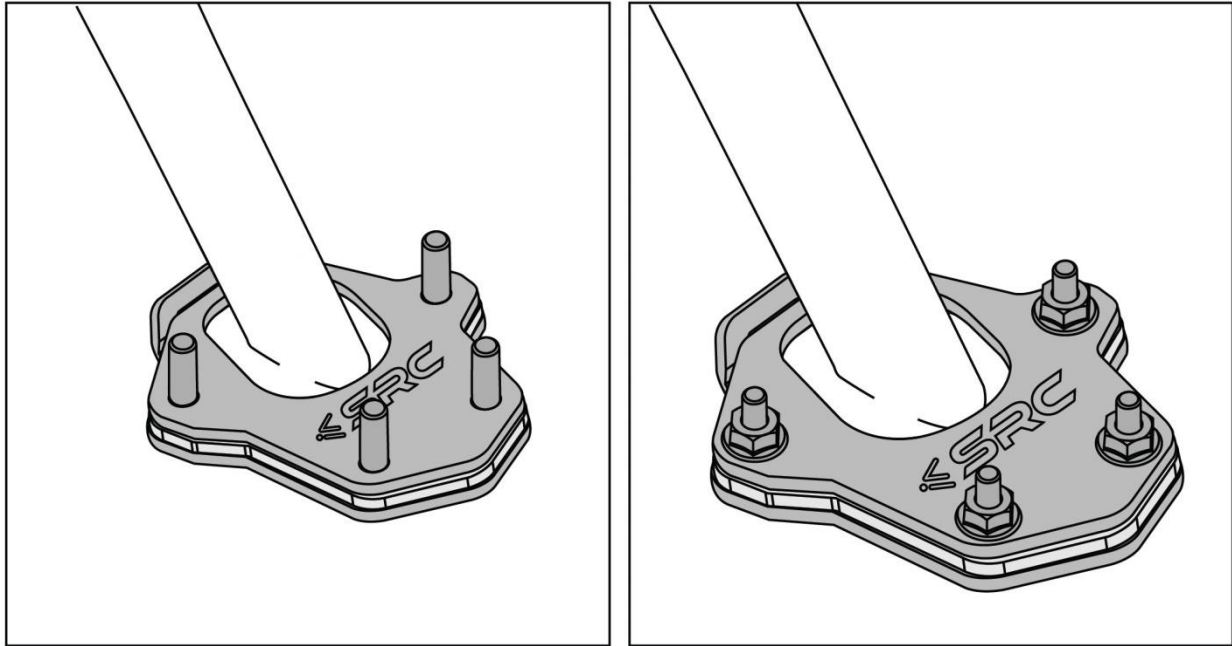
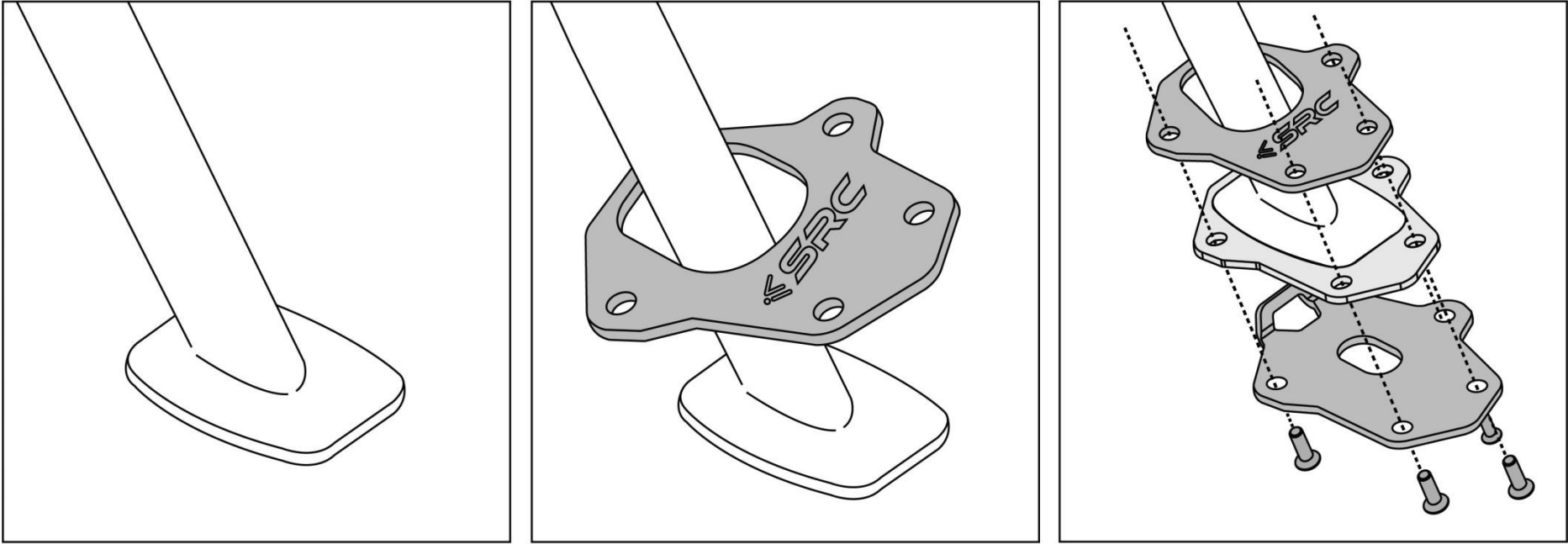

Mounting Instructions

Step 1:

During Mounting the Large Side Stand, let the Motorbike firmly rest on the floor, using the Centre Stand.

The side stand can be brought forward (position as shown in the drawing) to have access to the Mounting/ Assembly of the SRC Large Side Stand.

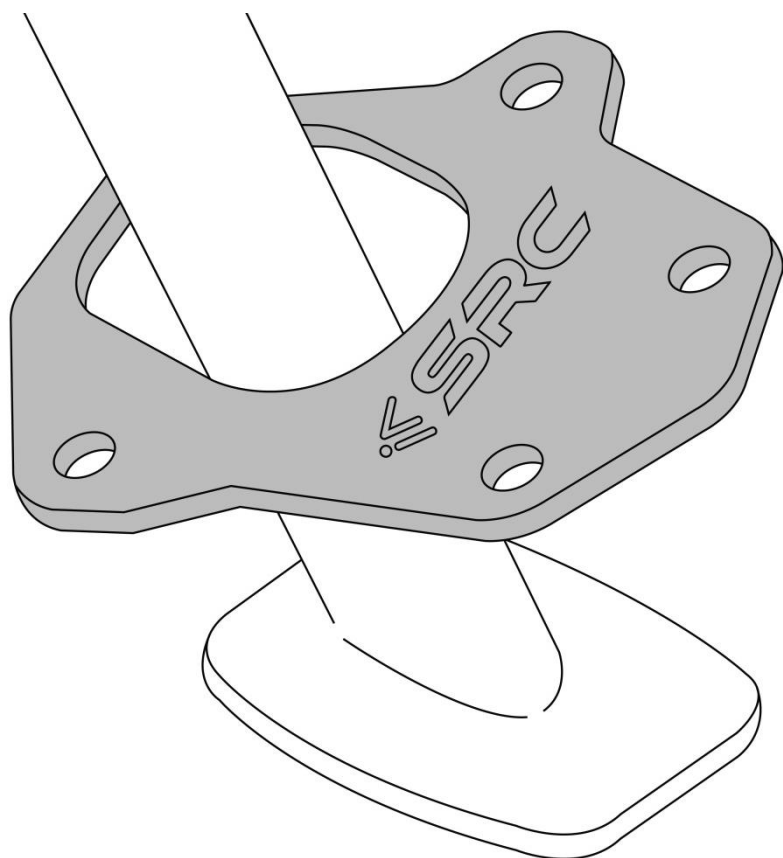
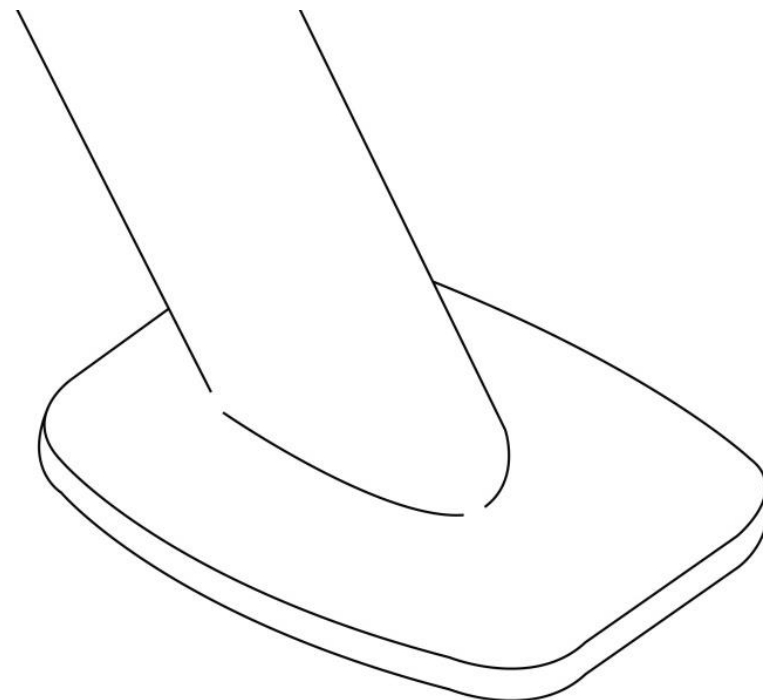

Step 2:

Orient the Top Plate (2), as shown, and the cut-out in the Top plate will comfortably clear the Side stand base

Step 3:

Orient and Align the Middle Plate (4) and Bottom Plate (1), all in-line, to the 4 Mounting holes.

The Inner walls of the Middle plate will closely hug with the outer walls of the Side stand.

The Bottom plate, will have a rear flap, which when mounted in-line with the 4 holes, suitably, sandwiches the 3 plates together.

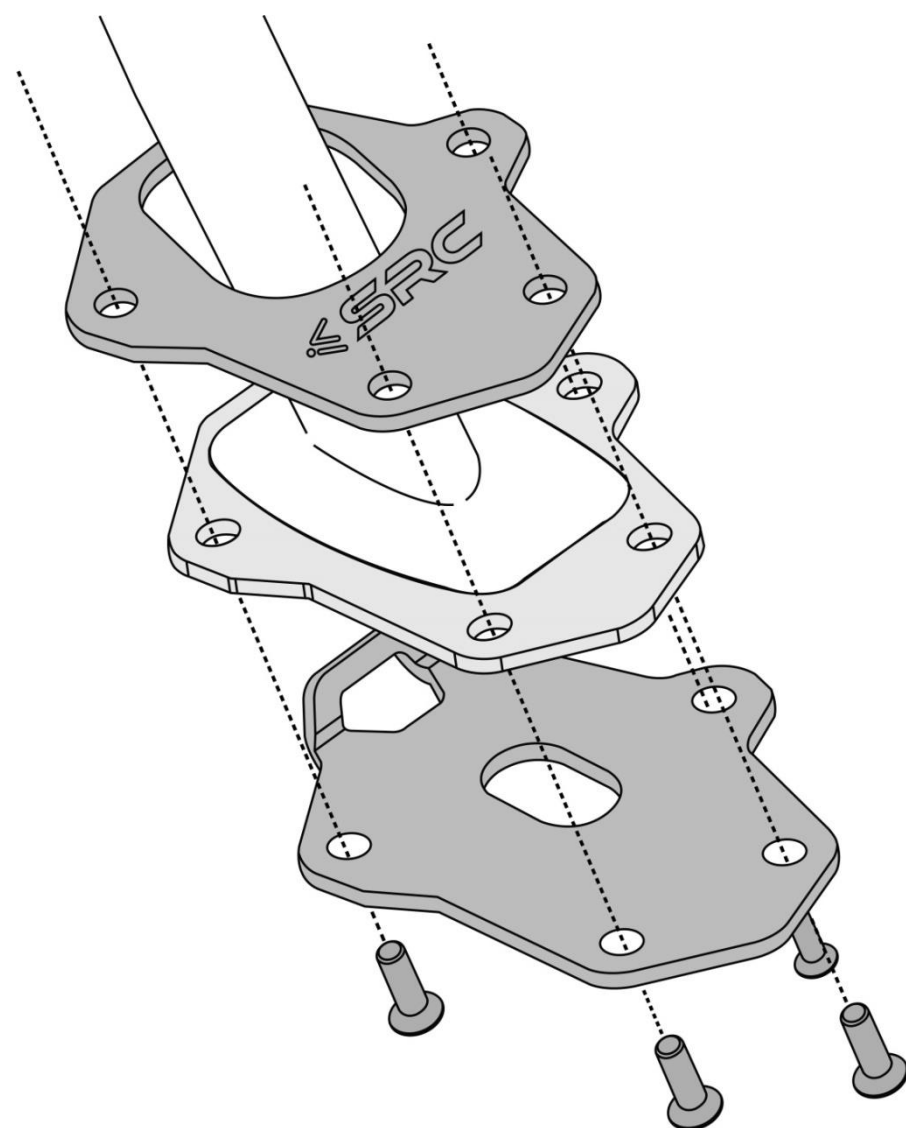

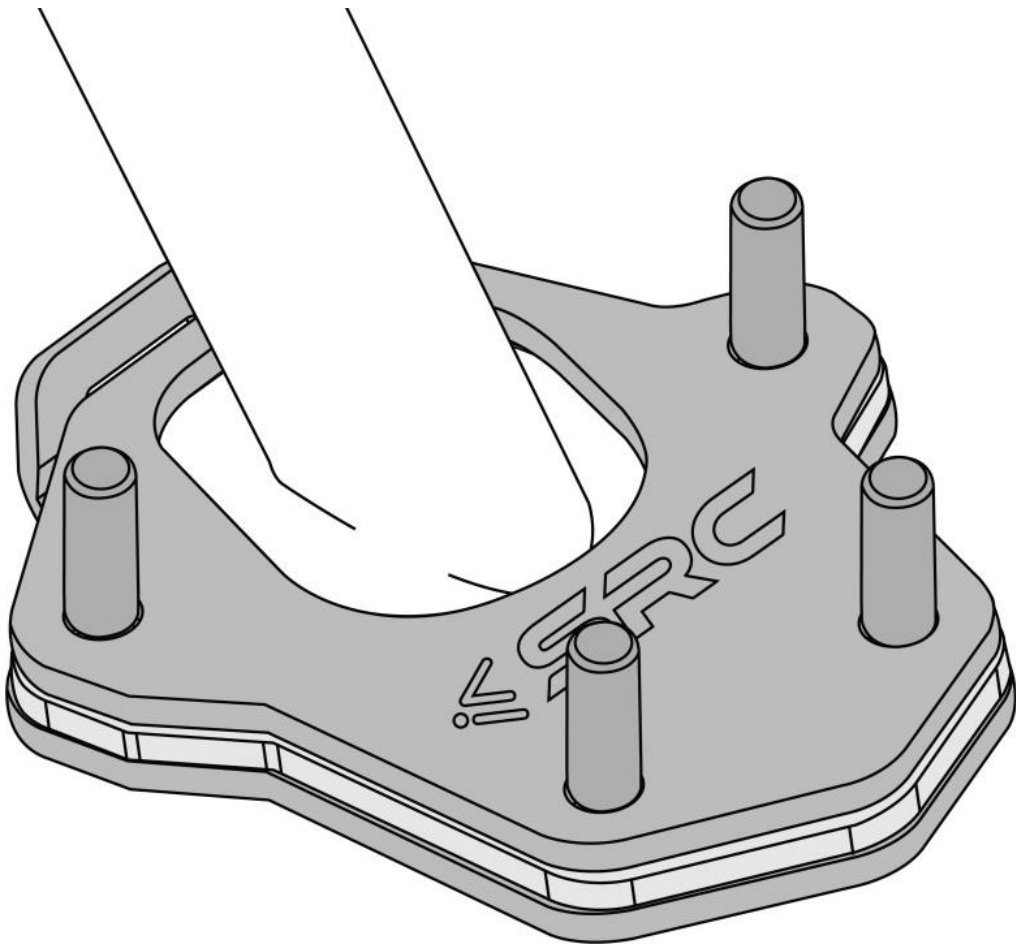

Step 4:

The 4 off M6 x 20 Countersink screws can be flushed from the bottom.

The countersink hole on the Bottom plate, flushes with the countersink head of the screws.

Step 5:

Secure the Threads on the Screws using 4 off Nut (4) M6 and tighten it fully to the torque specified in the BOM table.

The Top Head surface of the screws stays inside the surface of the bottom plate, when the screws are secured using the Nuts, so that when the Large Side Stand is released and the Motorbike is slanted for parking.

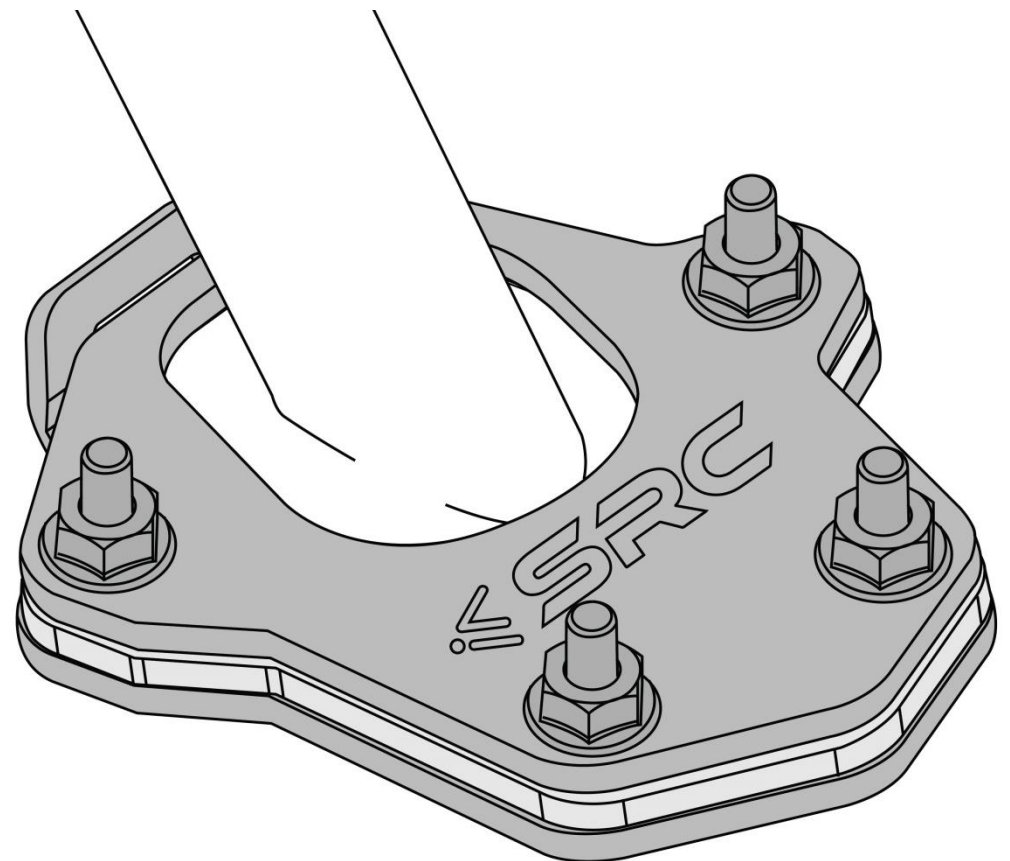
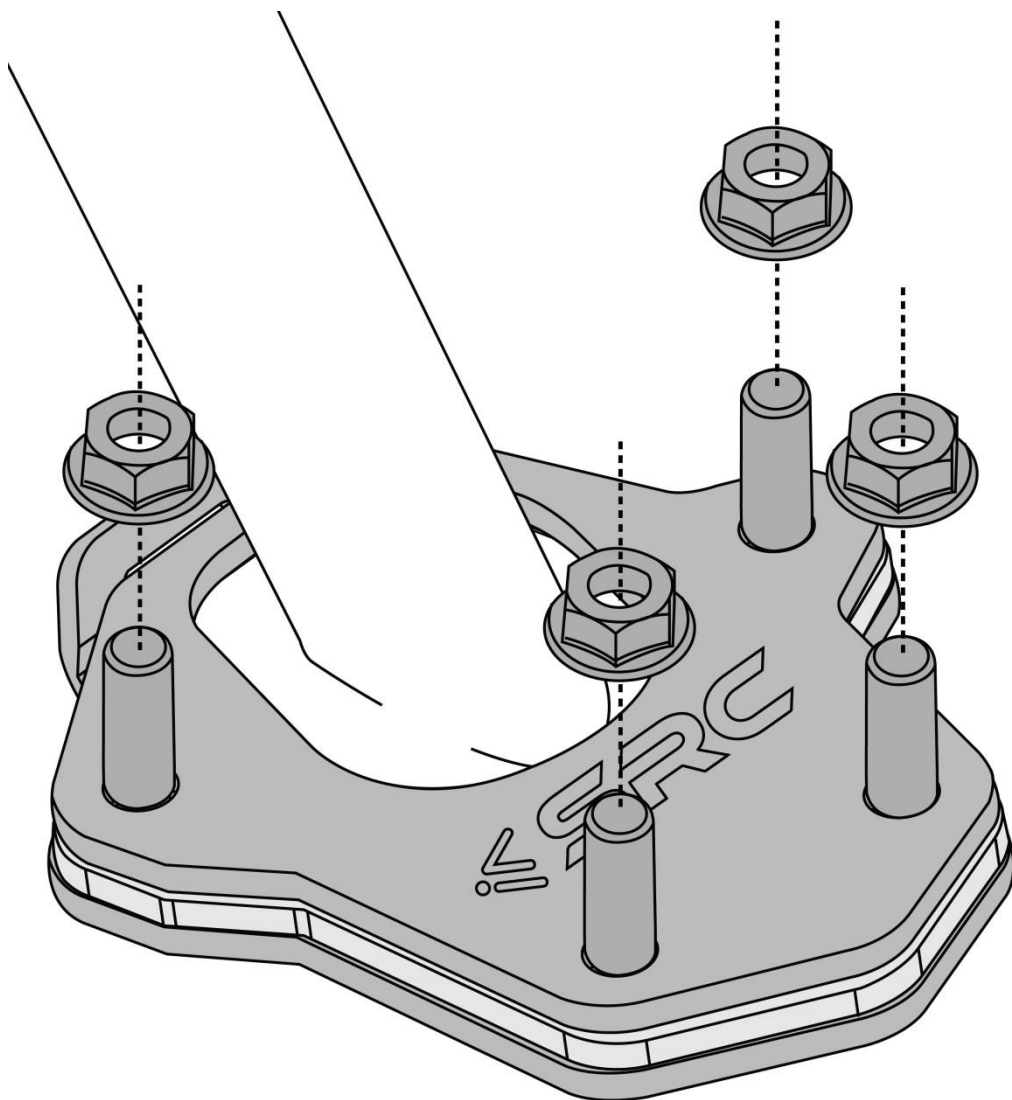



General Instructions

- 1. We request you to pay attention to the Mounting Instructions in this document and follow the step-by-step procedures.**
- 2. This Mounting Instruction manual is a “Do It Yourself” (DIY) fitment manual of the Accessory part to the Vehicle. We have prepared this based on our experience and knowledge, related to the Vehicle, Part and its functional aspects.**
- 3. SRC cannot guarantee the interchangeability of the parts to any other manufacturer’s accessory part. It is advised to the User, to inspect and ensure the original state of all other Vehicle parts.**
- 4. We request you to bear in mind, that the Installed part can change the driving behaviour and/or the stability during driving or any other dynamic conditions.**
- 5. If you have the appropriate tools and another person to assist you in the mounting, it will help.**
- 6. After Completion of the Mounting and before taking on a First ride, Ensure and Check all functions of the Vehicle. It is always advised to check loosening of the fasteners after the first 50 kilo meters of ride and at regular intervals.**
- 7. We are showing here the Scope of Supply/ Installation/Parts list & BOM from SRC**
- 8. To the maximum extent possible, our design use the current Mounting/Fitment of the Original Equipment, so that Installation of these accessories will not affect the Payload or Function of the Vehicle or the Part on which it is mounted to protect it**
- 9. If any additional modifications are to be done, prior to the fitment of the accessories, it will be explicitly specified in the instruction sheets.**