

Scope of Supply/Bill of Material & Mounting Drawings

Part Number: H-CB500X-14-01-SL

Part Description: Large Side Stand – Honda CB500 X

Installation / Parts List / Bill of Material for Mounting

NO.	Description	Quantity	Torque * (N-M)	Remarks **	Check List
1	Top Plate	1			
2	Countersink Screw M6 X 20	4			
3	Middle Plate	1			
4	Nut M6	4	9 - 10	Use Liquid Thread Locker	
5	Bottom Plate	1			

SRC Design uses Metric System of Measurement and all dimensions in Millimeters

* Recommended to use the Torque specified in the table

** Denotes Usage of Liquid Thread Locker in specified Locations

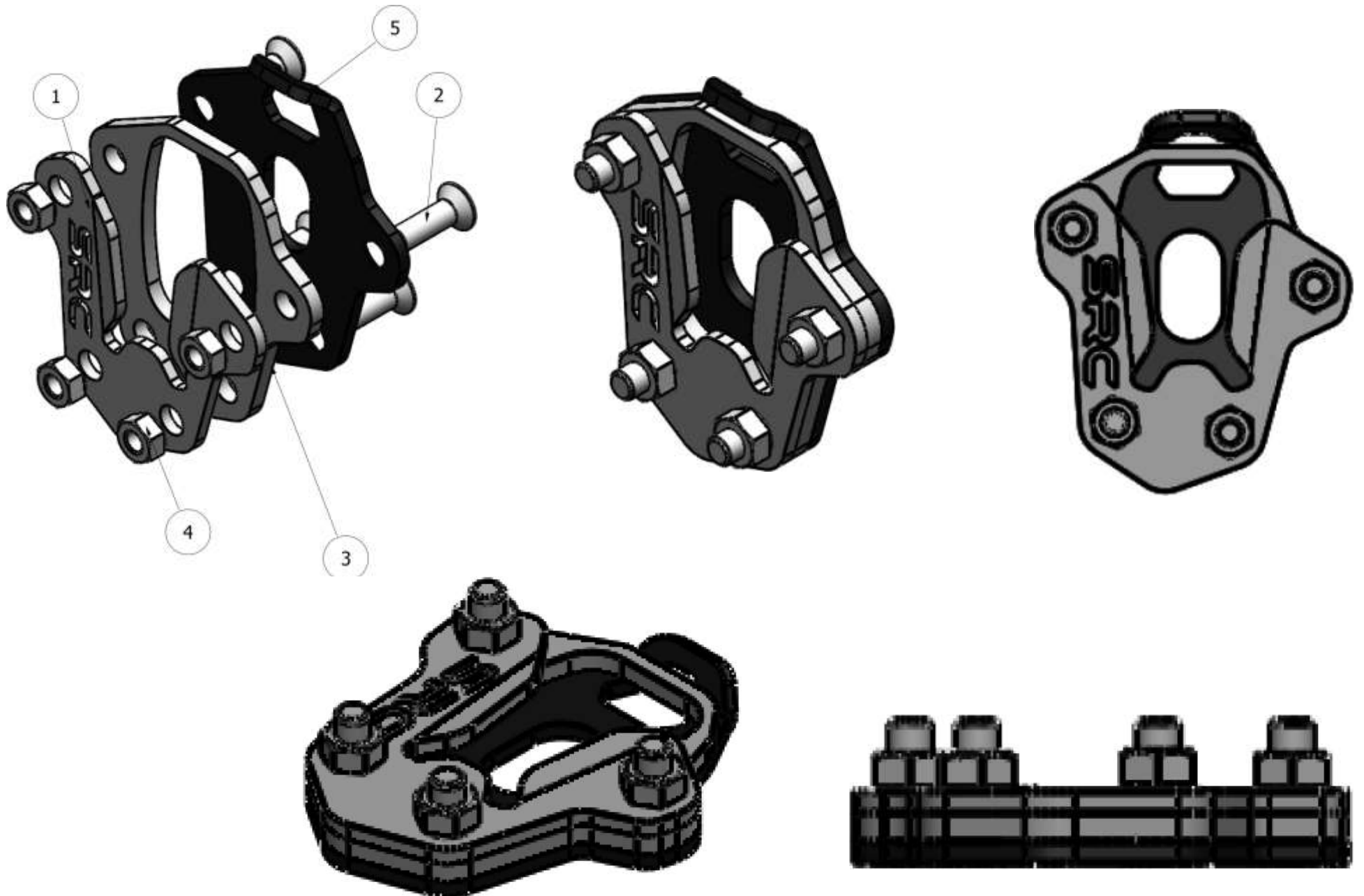

MOUNTING DRAWINGS

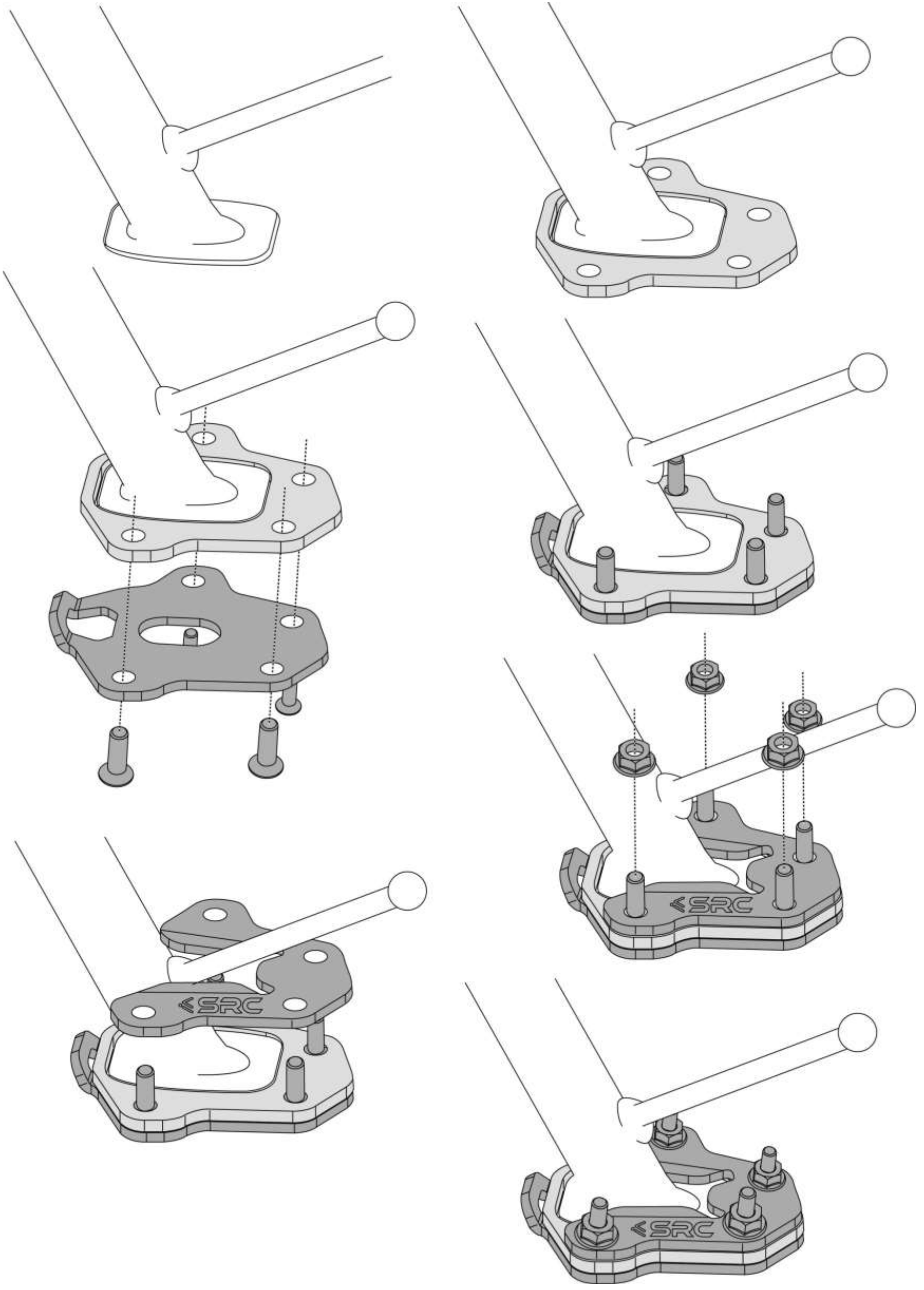

Mounting Instructions



The Motorbike has to be held using the central stand, and Side Stand, drawn to the sides, to have access to the mounting of Large Side stand.

Side Stand looks as shown, prior to the Start of the Installation of SRC Large Side Stand.

Step 1:

Orient and Slip-in the Middle Plate (3), as shown.

The peripheral Inner walls of the Middle plate, will closely hug the outer walls of the Side stand.

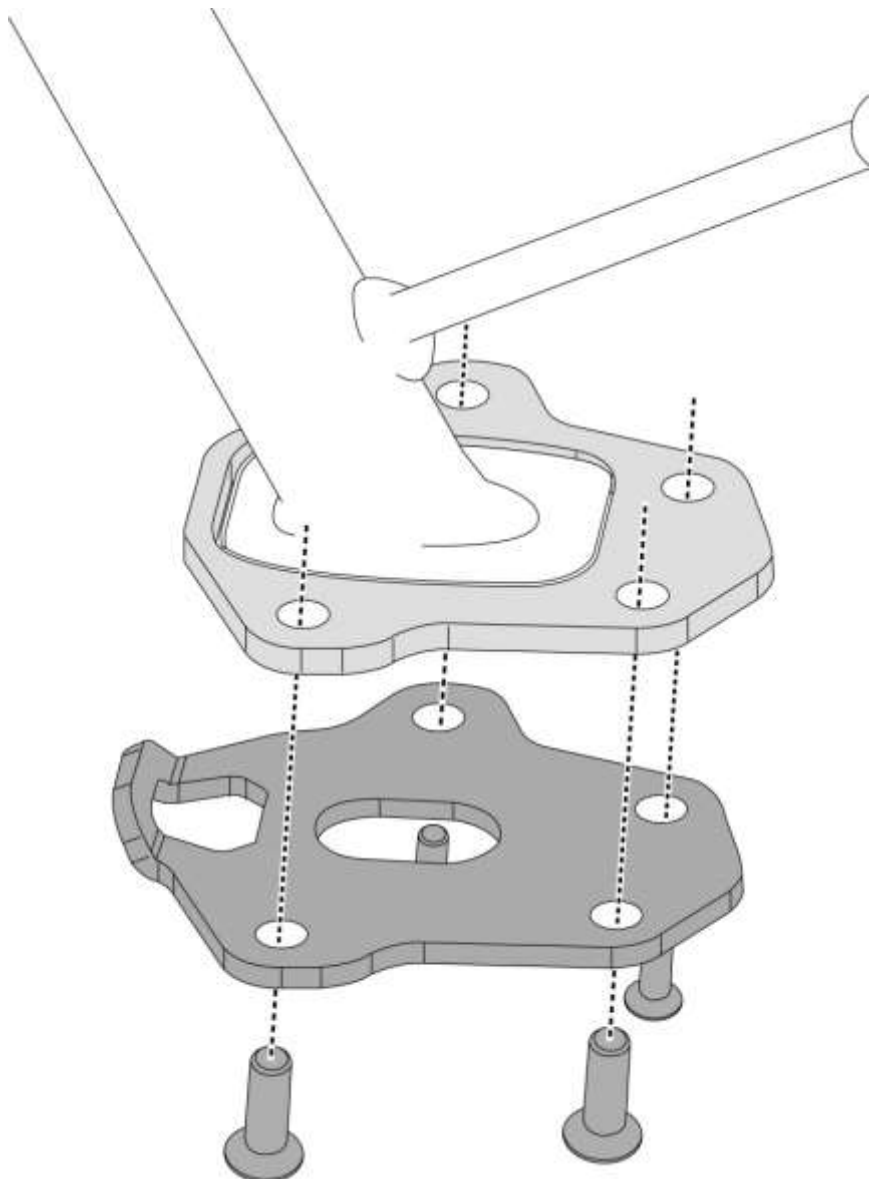
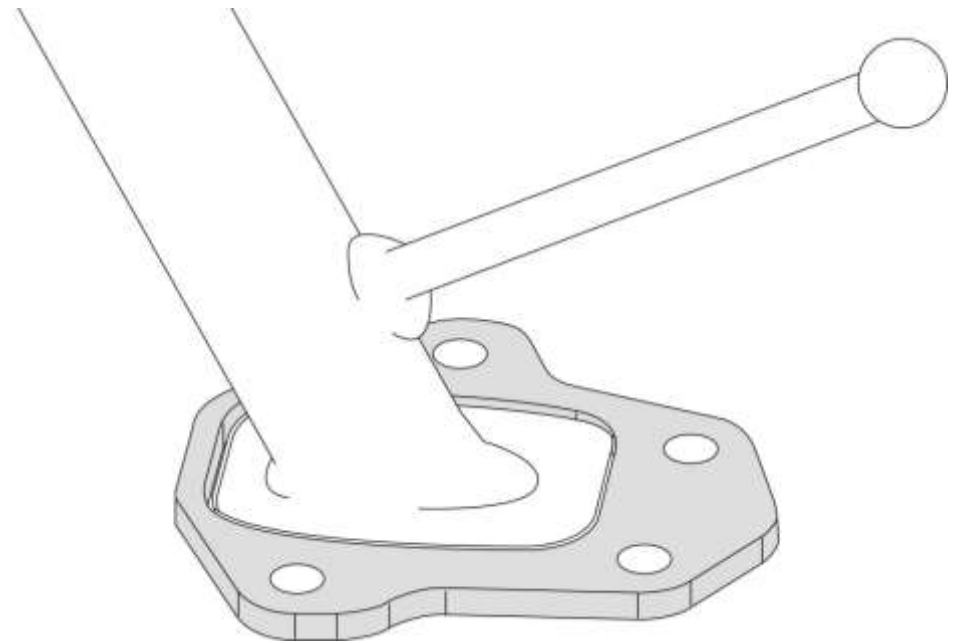

Step 2:

Orient the Bottom Plate (5), in-line with the Mounting Holes on the Middle Plate and slide-in the M6 Screws from the bottom side.

The Bottom plate has a rear side flap, which closely hugs the Rear Periphery of the Middle plate, to ensure orientation, as well as to ensure No slackness.

“As is Mounted condition “after Insertion of the M6 Screws from the Bottom side, and flushing the countersink contours of the screws and the Bottom plate.

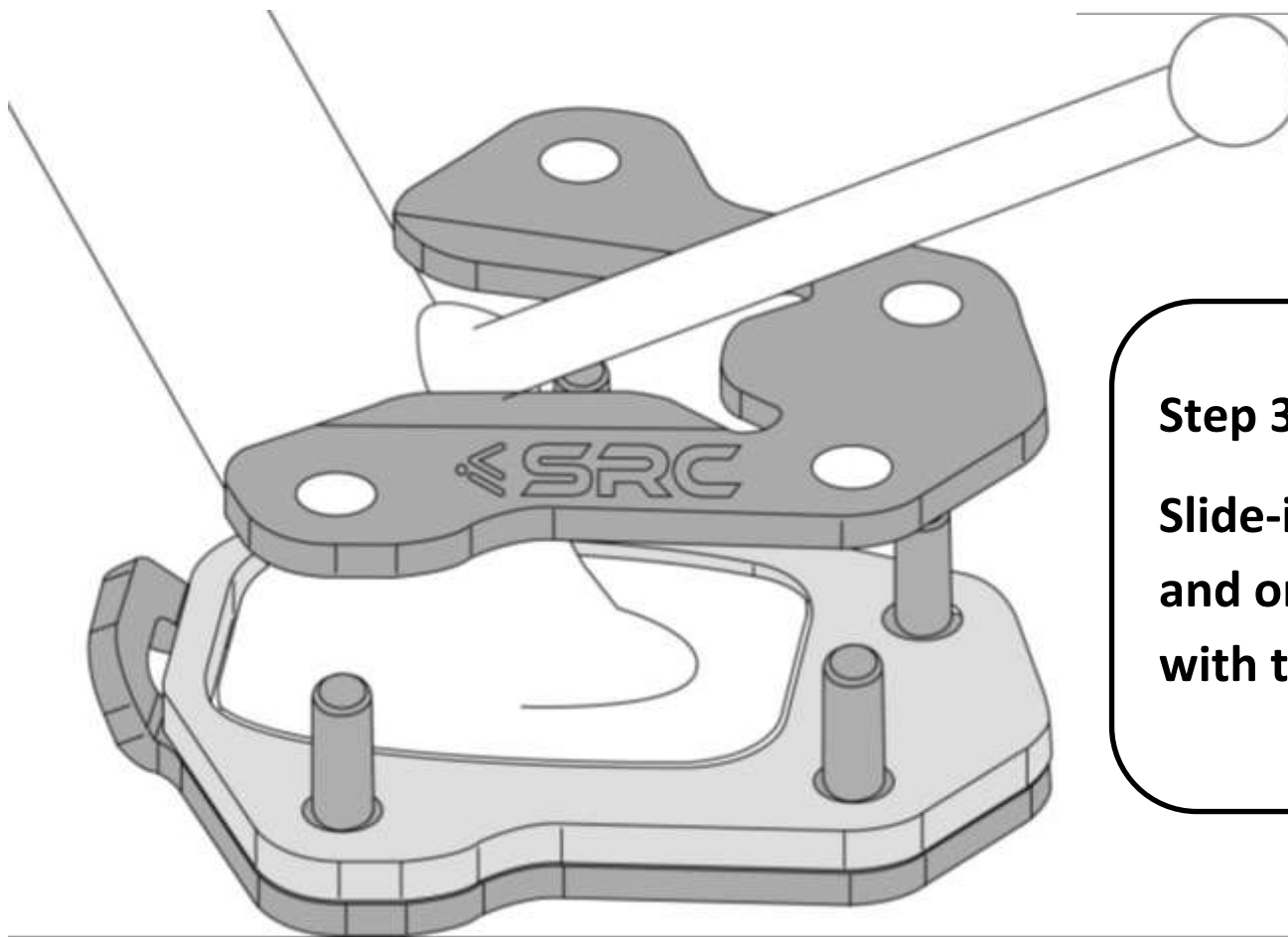
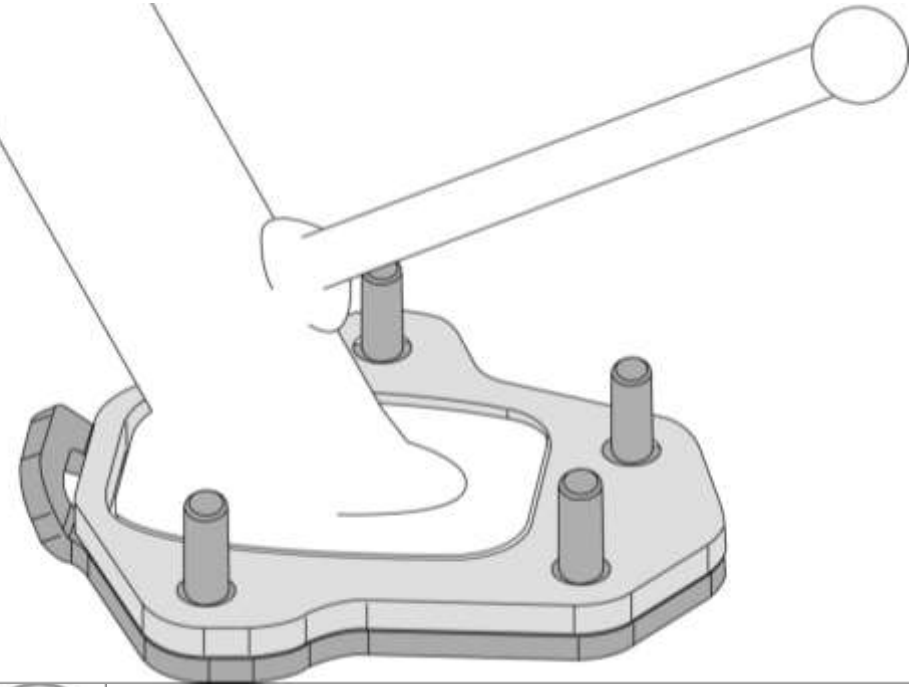

Step 3:

Slide-in the Top Plate (1), as shown and orient the mounting holes in-line with the 4 Projecting screws.

Step 4:

Secure the threads on the screw using M6 Nut (5), as shown.

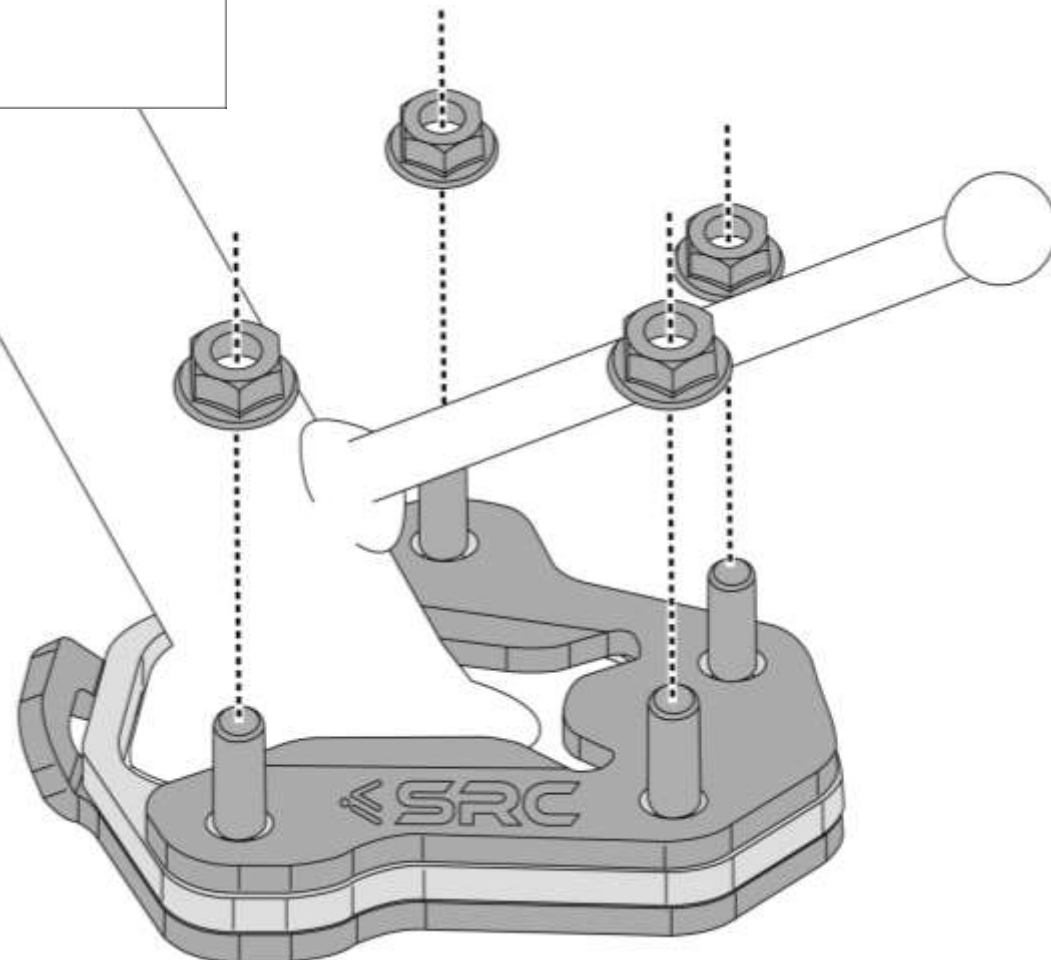

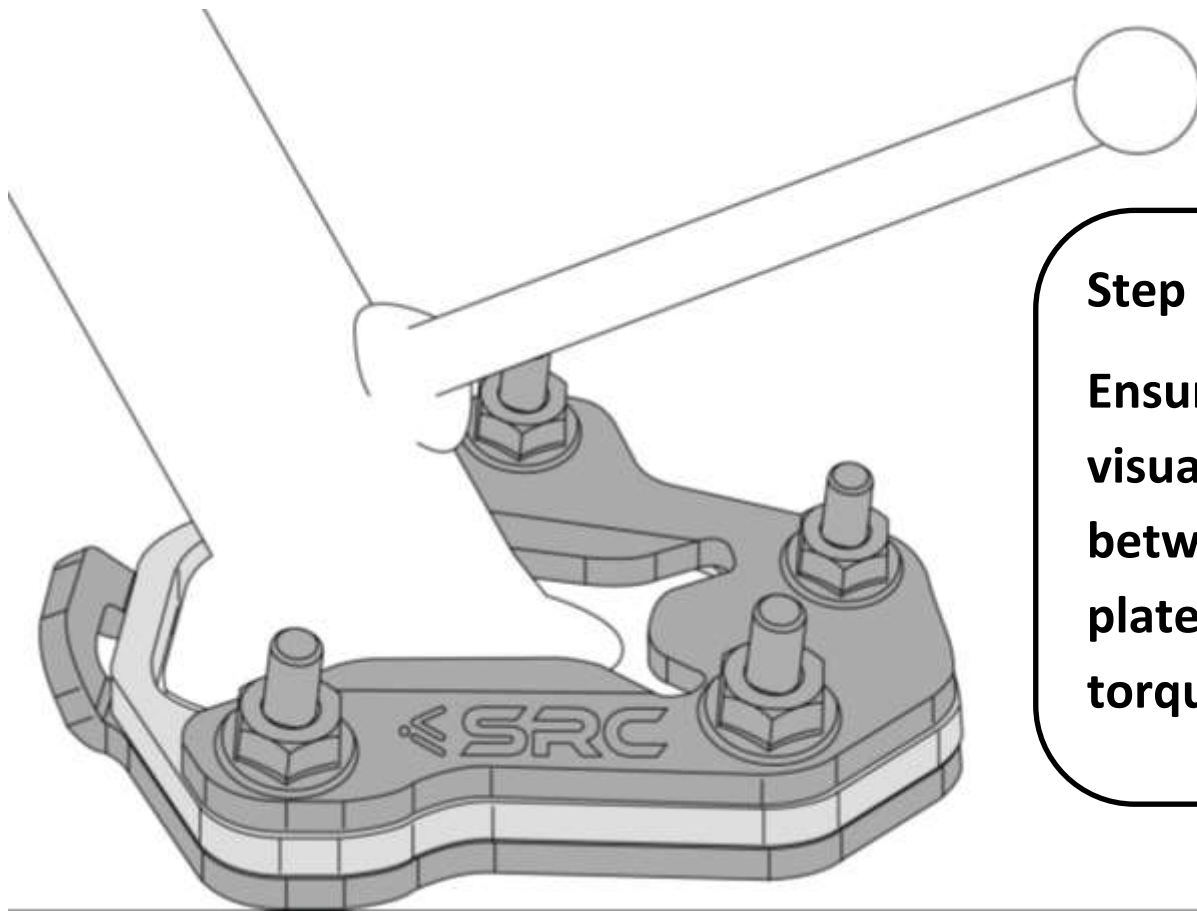

Step 6:

Ensure all Mounting orientations visually and ensure No slackness between the Top, Middle and Bottom plates, and tighten the Nuts to the torque as specified in the BOM table.



General Instructions

1. We request you to pay attention to the Mounting Instructions in this document and follow the step-by-step procedures.
2. This Mounting Instruction manual is a “Do It Yourself” (DIY) fitment manual of the Accessory part to the Vehicle. We have prepared this based on our experience and knowledge, related to the Vehicle, Part and its functional aspects.
3. SRC cannot guarantee the interchangeability of the parts to any other manufacturer’s accessory part. It is advised to the User, to inspect and ensure the original state of all other Vehicle parts.
4. We request you to bear in mind, that the Installed part can change the driving behaviour and/or the stability during driving or any other dynamic conditions.
5. If you have the appropriate tools and another person to assist you in the mounting, it will help.
6. After Completion of the Mounting and before taking on a First ride, Ensure and Check all functions of the Vehicle. It is always advised to check loosening of the fasteners after the first 50 kilo meters of ride and at regular intervals.
7. We are showing here the Scope of Supply/ Installation/Parts list & BOM from SRC
8. To the maximum extent possible, our design use the current Mounting/Fitment of the Original Equipment, so that Installation of these accessories will not affect the Payload or Function of the Vehicle or the Part on which it is mounted to protect it
9. If any additional modifications are to be done, prior to the fitment of the accessories, it will be explicitly specified in the instruction sheets.