

Scope of Supply/Bill of Material & Mounting Drawings

Part Number: BMW-F750GS-15-01-SL / BMW-F750GS-15-02

Part Description: Rear Brake Reservoir Cover Guard – BMW F750 GS / F850 GS

Installation / Parts List / Bill of Material for Mounting

NO.	Description	Quantity	Torque * (N-M)	Remarks **
1	Rear Brake Reservoir Cover Guard	1		
SRC Design uses Metric System of Measurement and all dimensions in Millimeters				
* Recommended to use the Torque specified in the table				
** Denotes Usage of Liquid Thread Locker in specified Locations				

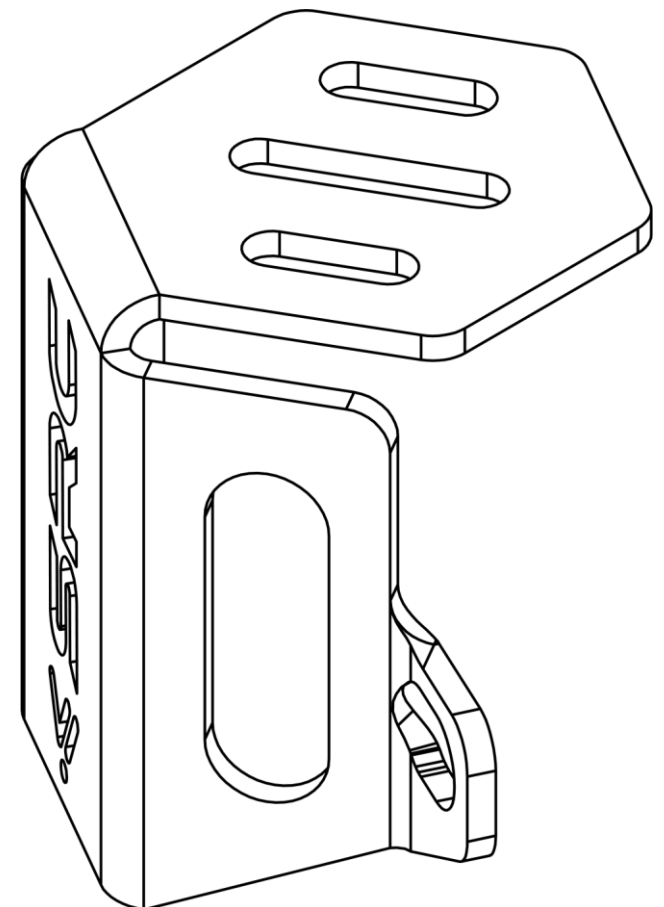
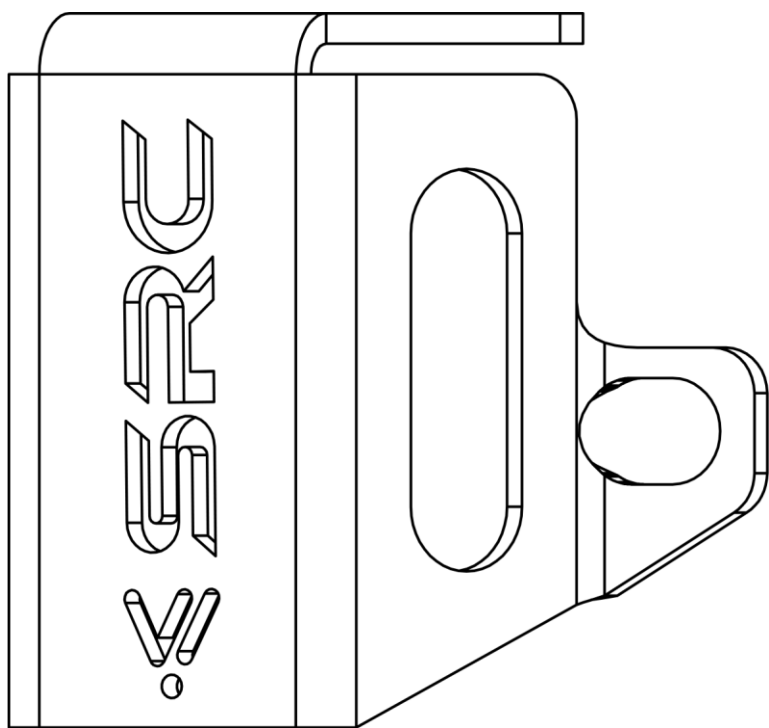

Mounting Drawings

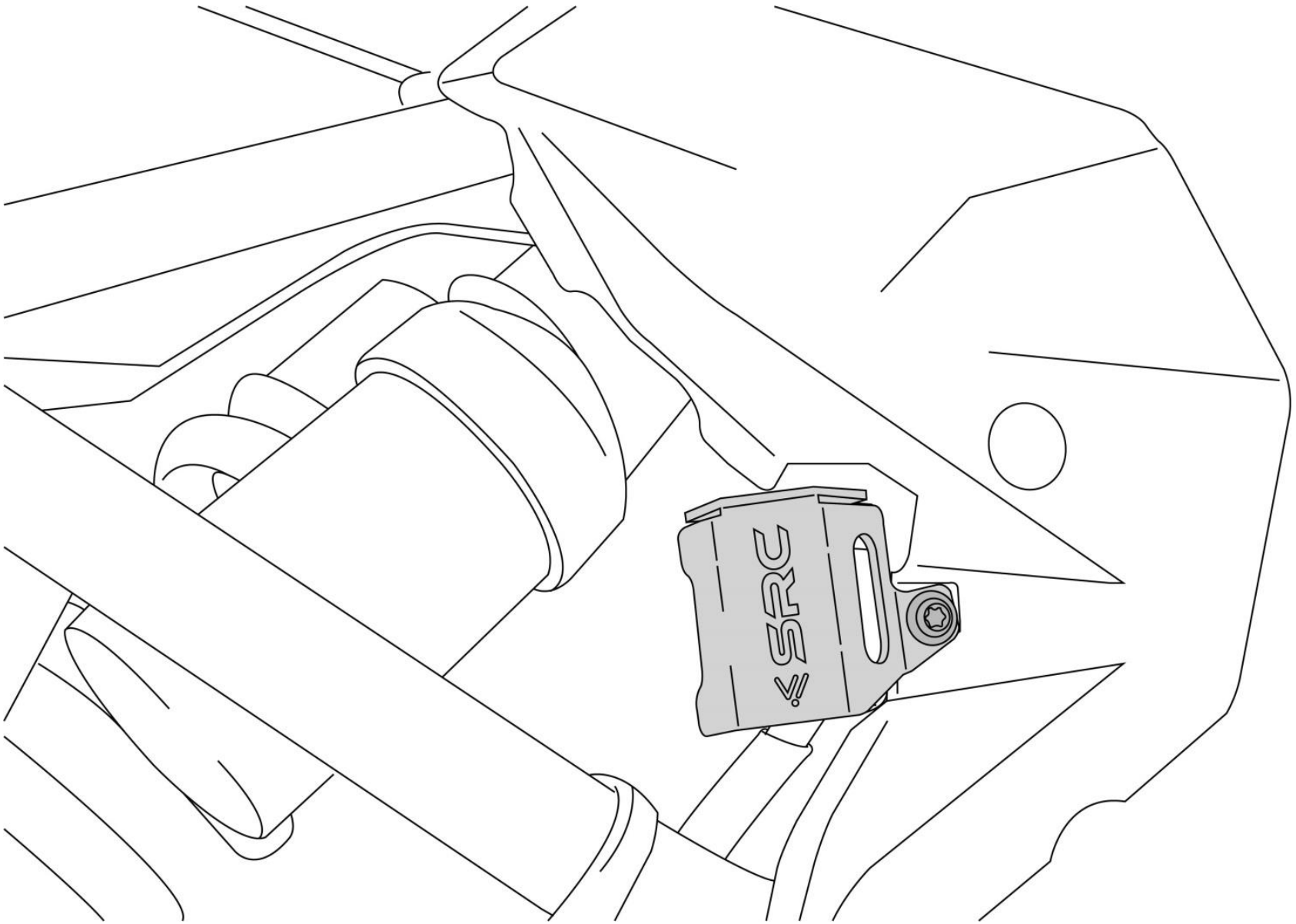
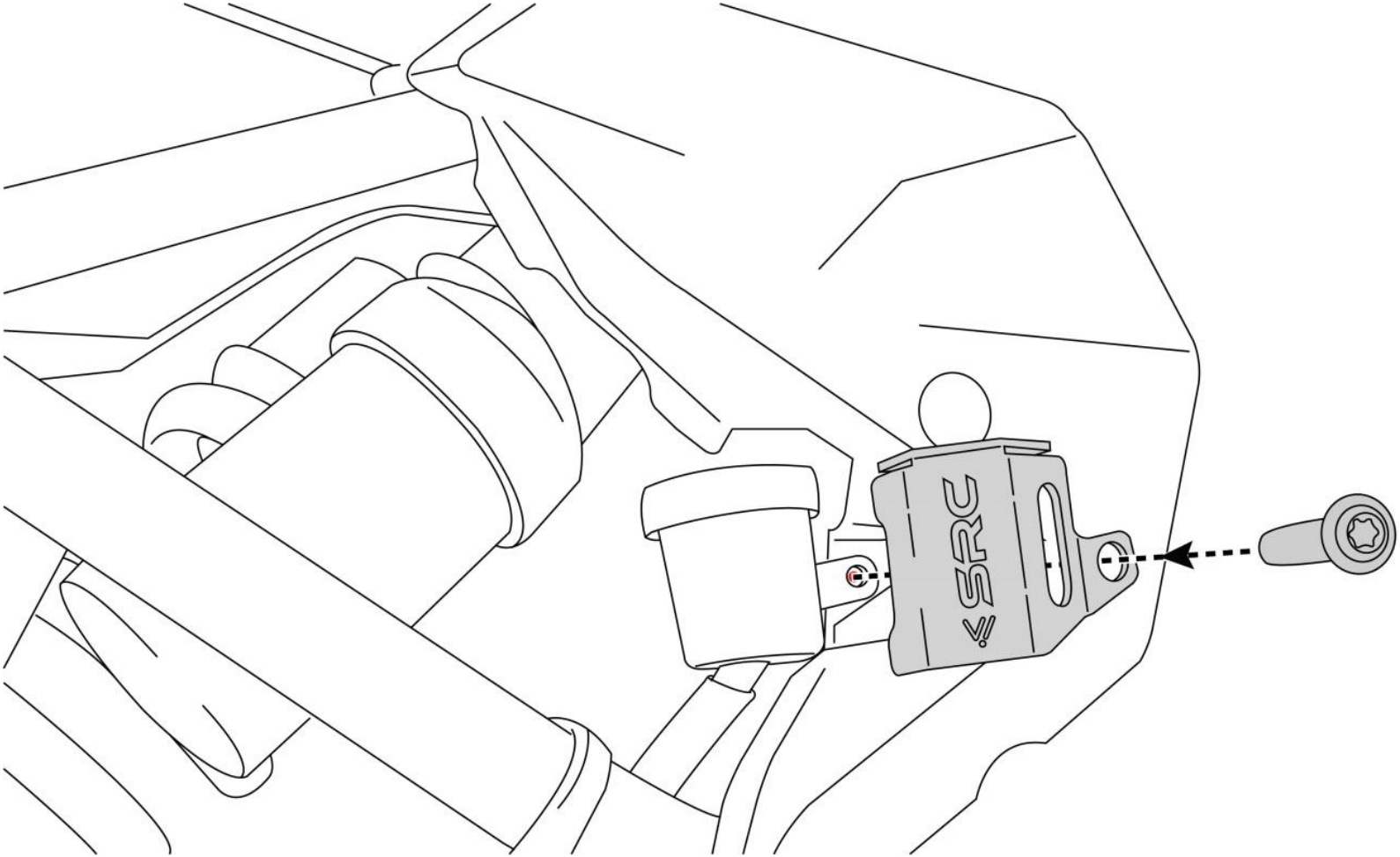

Mounting Instructions

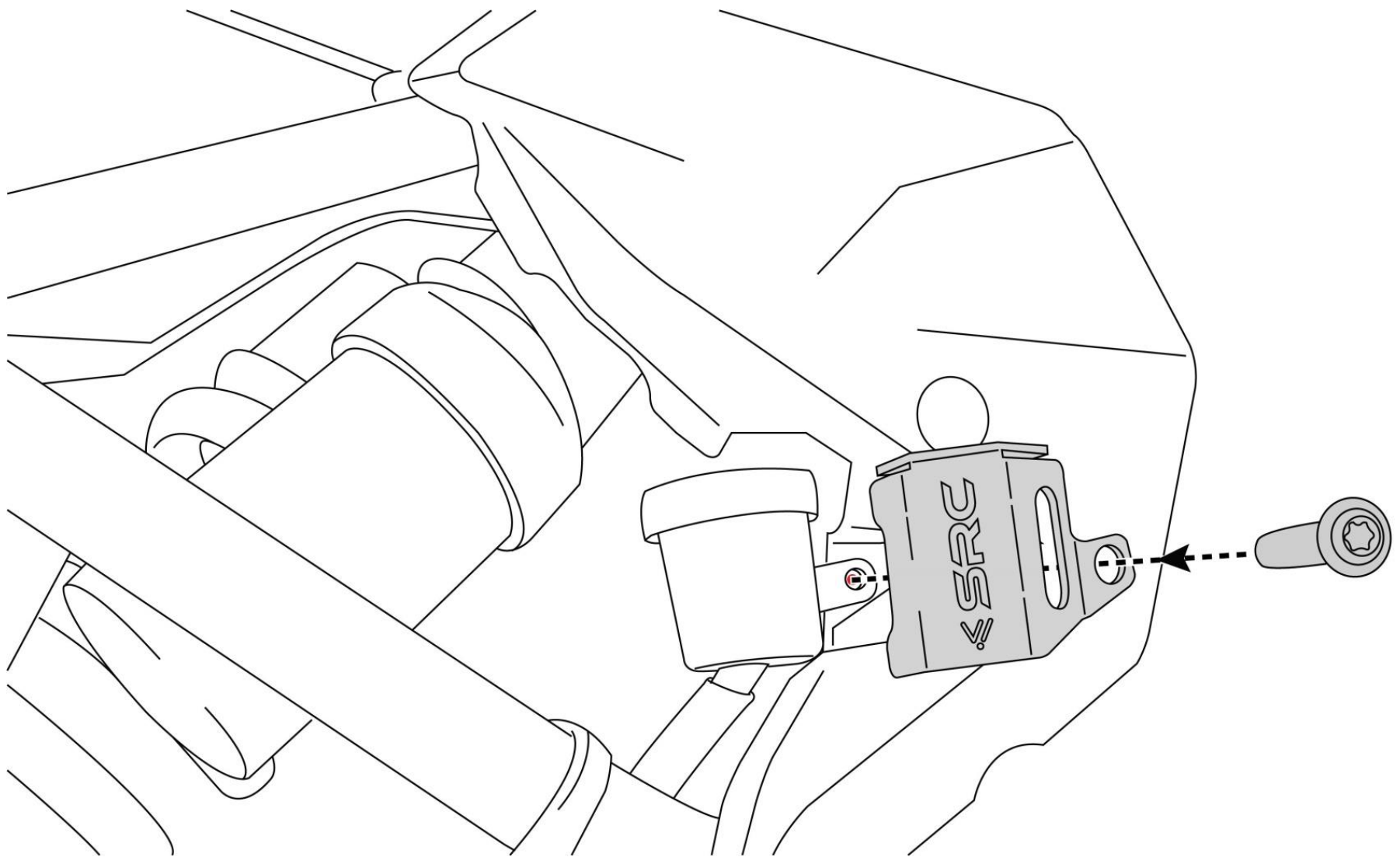

Step: 1

The Mounting Hole Identified in “Red” is already available in the Motorbike, which is used for mounting the Rear Brake Fluid Reservoir. Remove the Screw and Washer and Insert the SRC Rear Brake Reservoir Metal Cover as shown and tighten the screw.

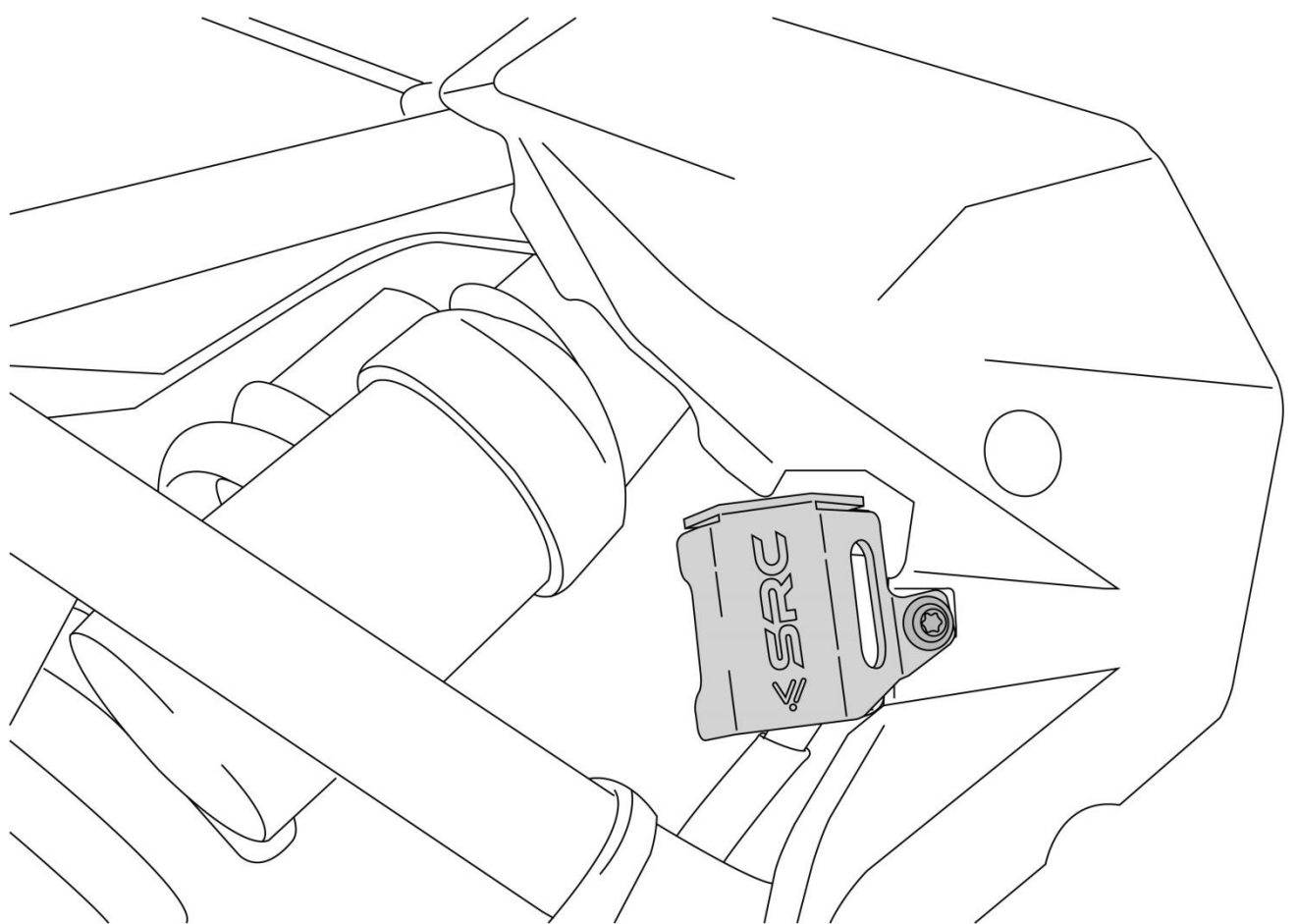



General Information

1. We request you to pay attention to the Mounting Instructions in this document and follow the step-by-step procedures.
2. This Mounting Instruction manual is a “Do It Yourself” (DIY) fitment manual of the Accessory part to the Vehicle. We have prepared this based on our experience and knowledge, related to the Vehicle, Part and its functional aspects.
3. SRC cannot guarantee the interchangeability of the parts to any other manufacturer’s accessory part. It is advised to the User, to inspect and ensure the original state of all other Vehicle parts.
4. We request you to bear in mind, that the Installed part can change the driving behaviour and/or the stability during driving or any other dynamic conditions.
5. If you have the appropriate tools and another person to assist you in the mounting, it will help.
6. To the maximum extent possible, our design use the current Mounting/Fitment of the Original Equipment, so that Installation of these accessories will not affect the Payload or Function of the Vehicle or the Part on which it is mounted to protect it
7. If any additional modifications are to be done, prior to the fitment of the accessories, it will be explicitly specified in the instruction sheets.